

# 4140 Post to Post Style System

Rails • Balusters • Shoerail • Fillet

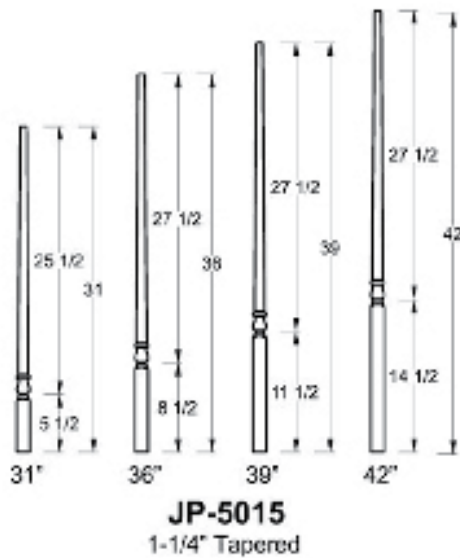

**JP-6050 Oak/Maple**

Fillet



**JP-6045 Oak/Maple**

Shoe



**JP-6050 Hemlock**

Fillet



**JP-6045 Hemlock**

Shoe

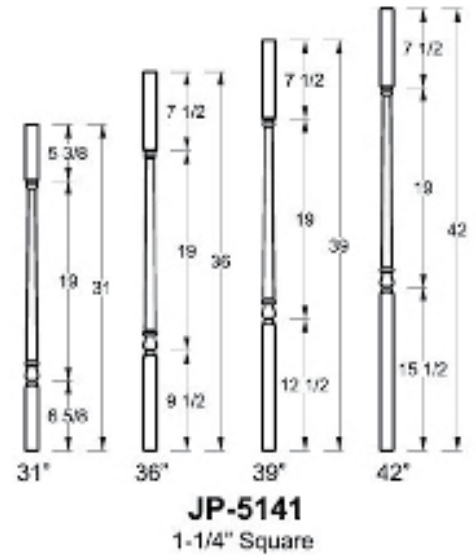

Each baluster is pre-drilled with a 9/32" diameter hole 3" deep into which a provided wood dowel can be inserted.

Every baluster can then be installed in the traditional manner, or installed by using a dowel screw.

## Newels

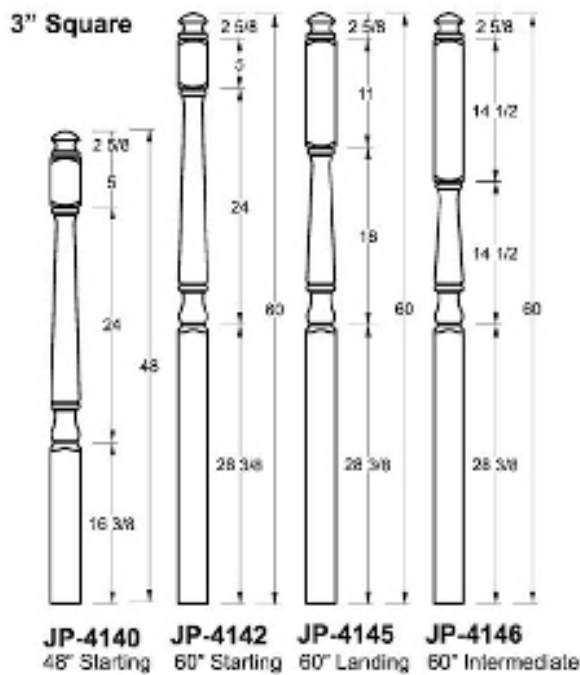

2 1/4"



2 3/8"



2 3/8"

1 1/4" Plow

**JP-6010P**

2 1/4"



2 3/8"



2 3/8"

**JP-6010**



# 4014 Over the Post Style System

Rails • Balusters • Shoerail • Fillet

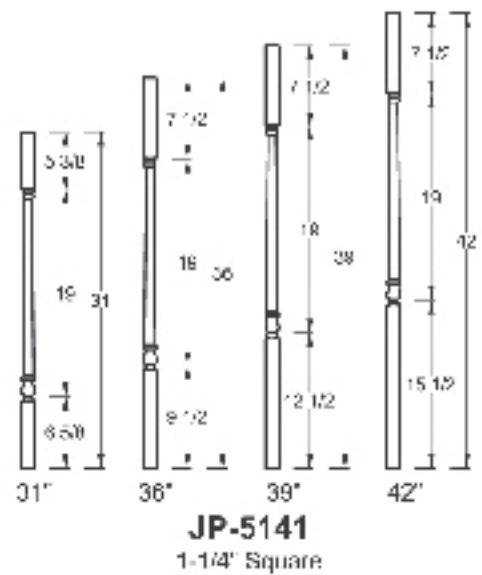
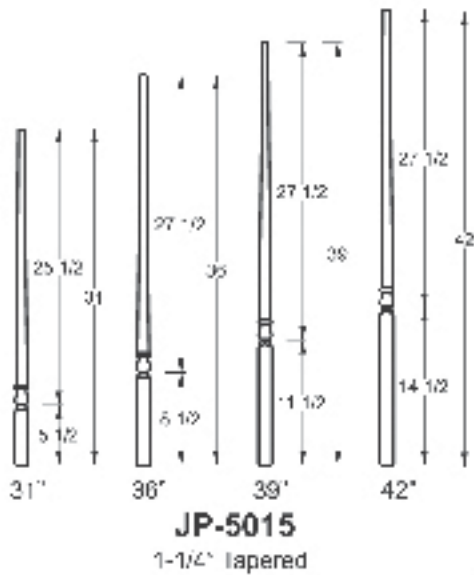

Each baluster is pre-drilled with a 9/32" diameter hole 3" deep into which a provided wood dowel can be inserted.  
Every baluster can then be installed in the traditional manner, or installed by using a dowel screw.

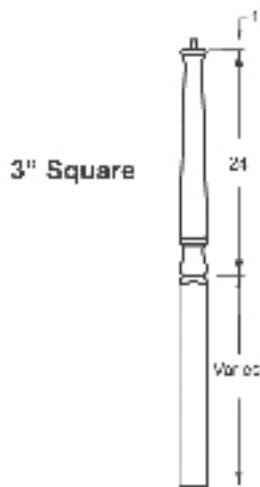

- JP-4014**  
48" Starting
- JP-4015**  
60" Intermediate
- JP-4019**  
84" Winder

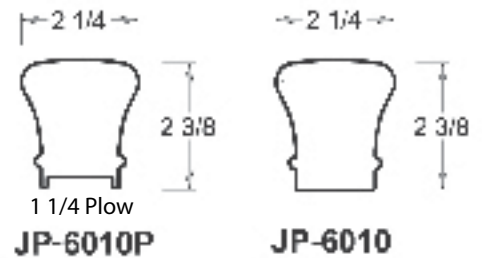



# 4500 Post to Post Style System

Rails • Balusters • Shoerail • Fillet

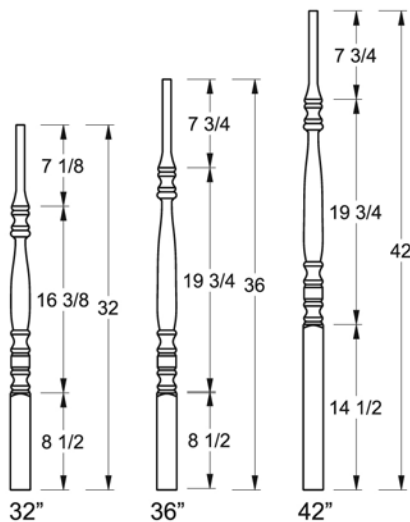

## JP-5300

1-5/8" Square Hemlock  
1-3/4" Square Oak

## JP-6007 Oak

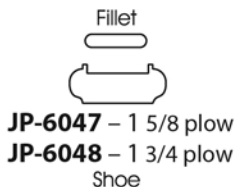

## JP-6007 Hem



## JP-6046 Hem



Each baluster comes with a wood dowel and can then be installed in the traditional manner, or installed by using a dowel screw.

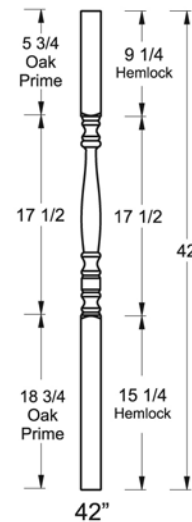
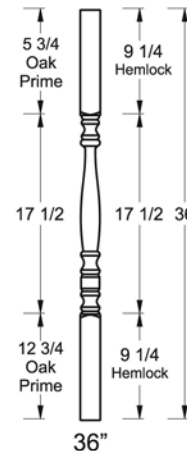
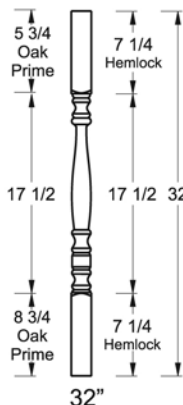

## JP-5005

1-5/8" Square Hemlock  
1-3/4" Square Oak  
1-3/4" Square Primed

## Newels

### 3" Square

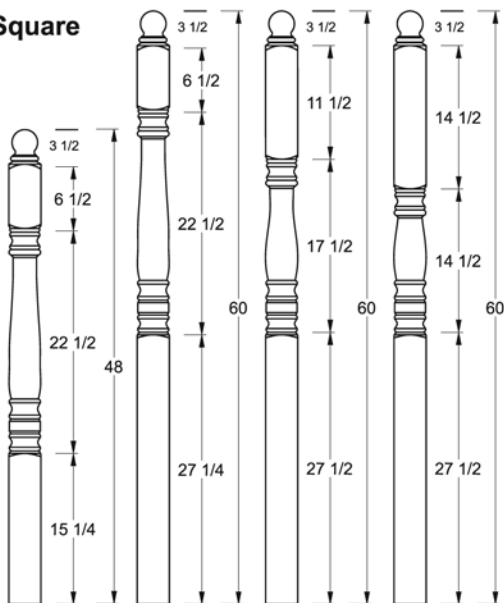

## JP-4500

48" Starting

## JP-4502

60" Starting

## JP-4505

60" Landing

## JP-4506

60" Intermediate



## JP-6519

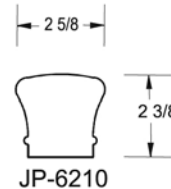

## JP-6210

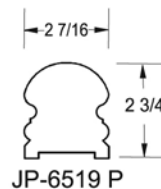

## JP-6519 P

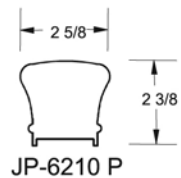

## JP-6210 P

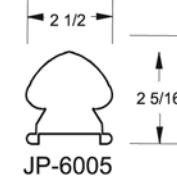

## JP-6005

## PLOW Size

Hardwood 1 3/8"  
Hemlock 1 5/8"



# 4514 Over the Post Style System

Rails • Balusters • Shoerail • Fillet

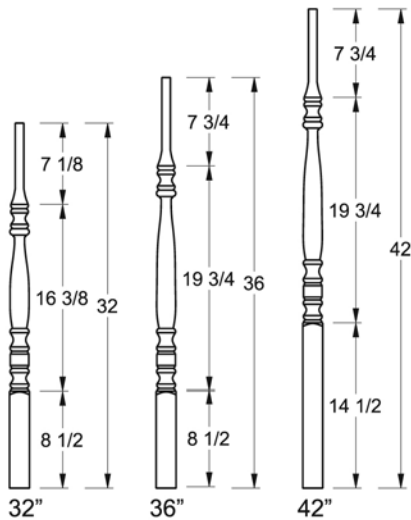

## JP-5300

1-5/8" Square Hemlock  
1-3/4" Square Oak

## JP-6007 Oak

Fillet



## JP-6047 - 1 5/8 plow

## JP-6048 - 1 3/4 plow

Shoe

## JP-6007 Hem

Fillet



## JP-6046 Hem

Shoe



Each baluster comes with a wood dowel and can then be installed in the traditional manner, or installed by using a dowel screw.

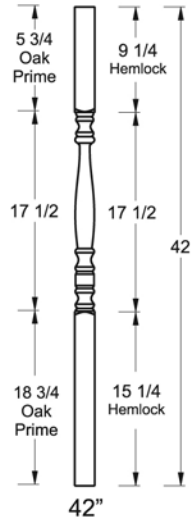
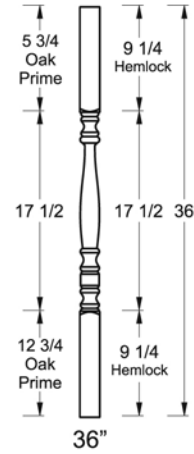
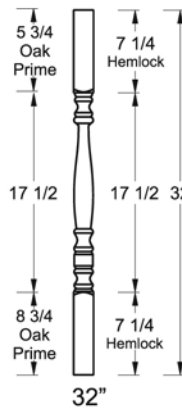

## JP-5005

1-5/8" Square Hemlock  
1-3/4" Square Oak  
1-3/4" Square Primed

## Newels

3" Square

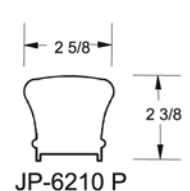
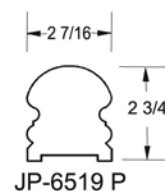
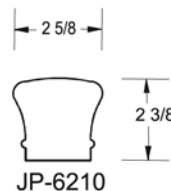
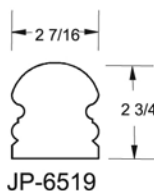
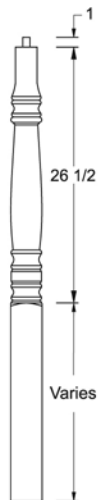

## PLOW Size

Hardwood 1 3/8"  
Hemlock 1 5/8"

JP-4514  
48" Starting

JP-4515  
60" Intermediate



# Handrail Fittings

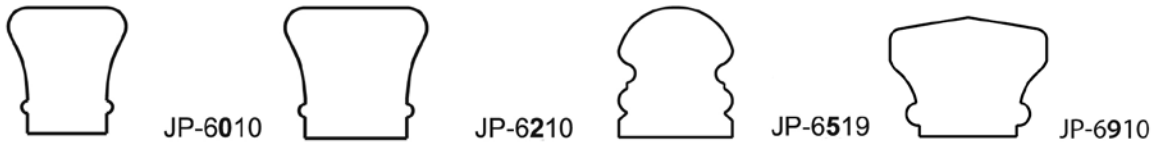

Note: Second number denotes handrail pattern!

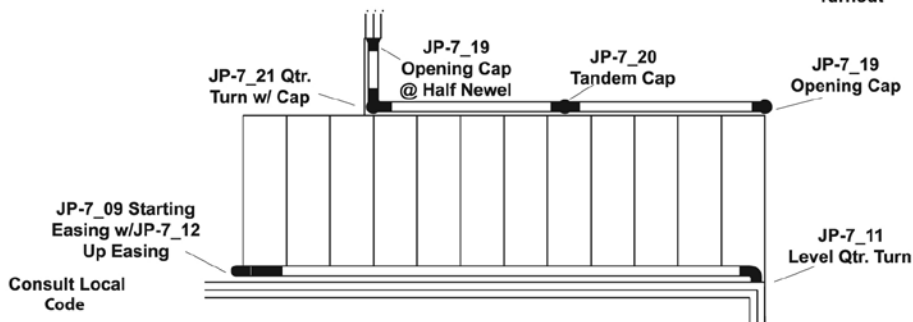
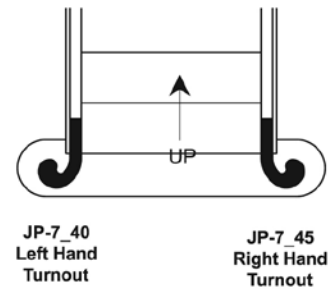
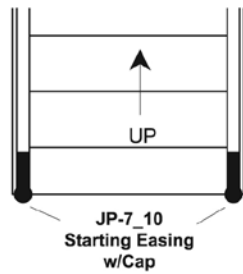
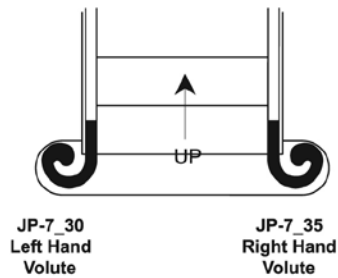
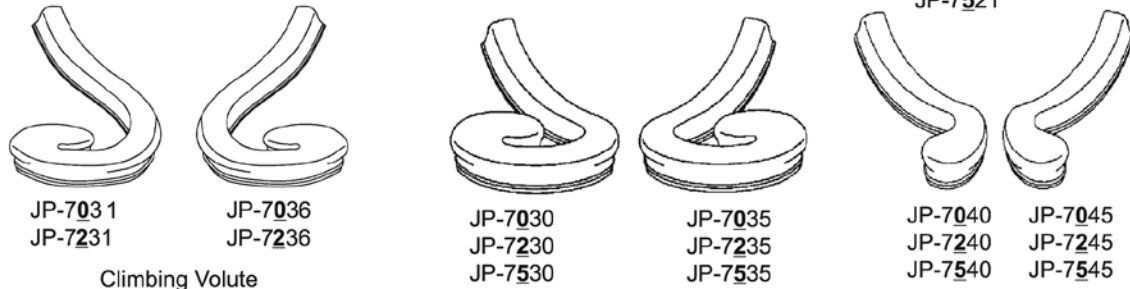
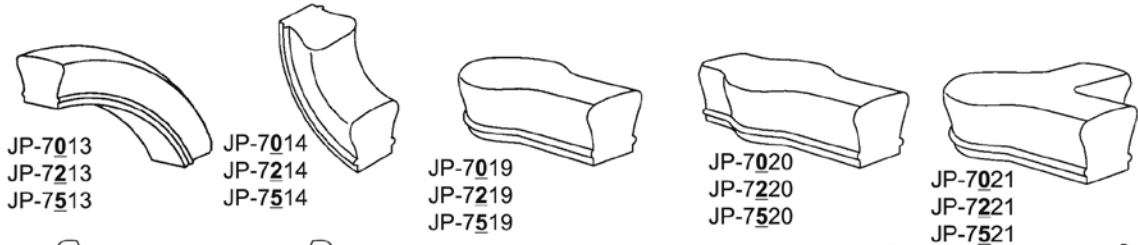
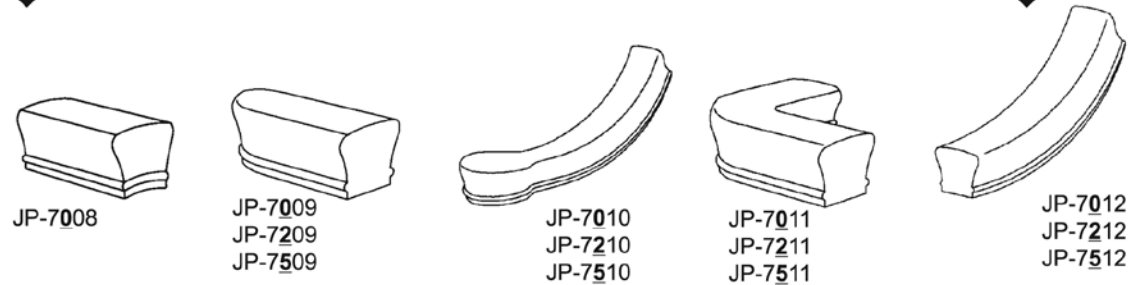



# Handrail Fittings

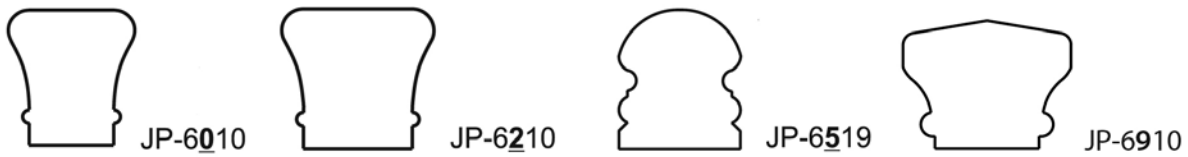

Note: Second number denotes handrail pattern!

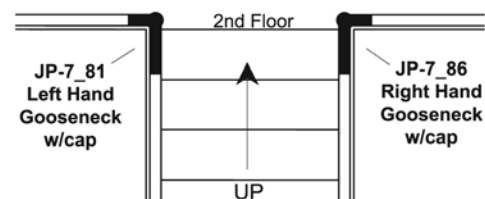
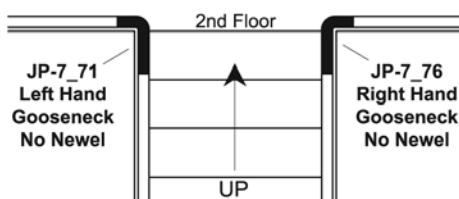
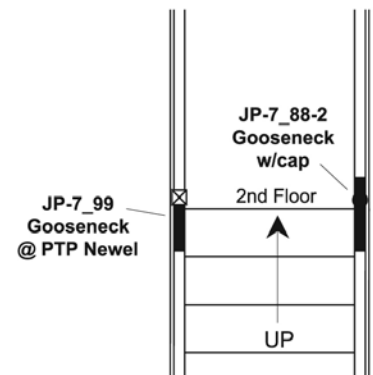
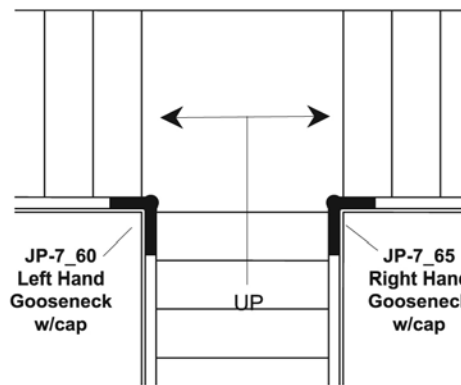
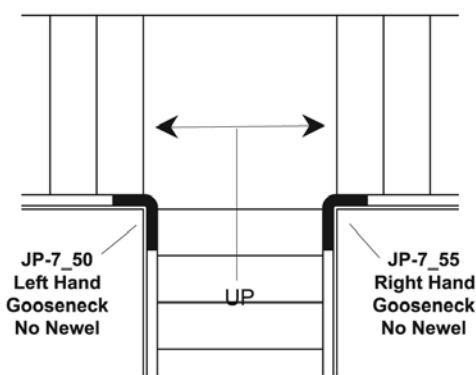
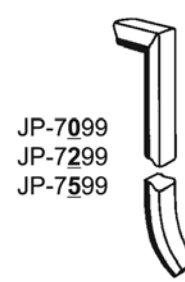
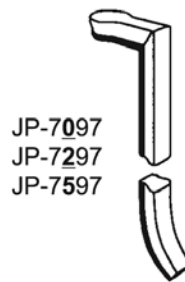
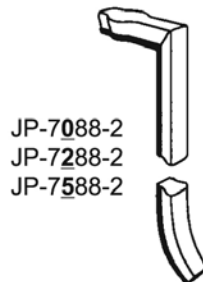
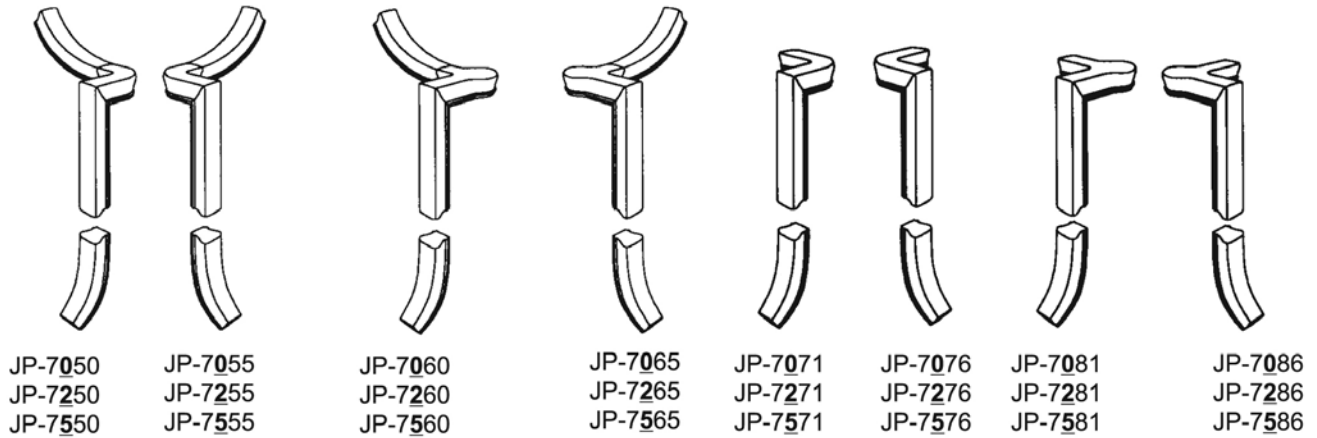



# Handrail Profiles

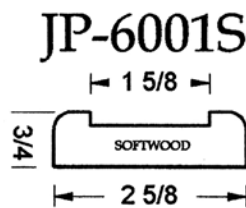
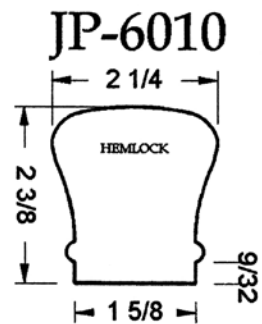
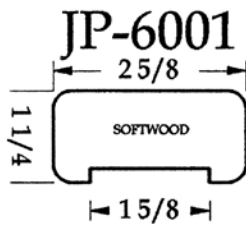
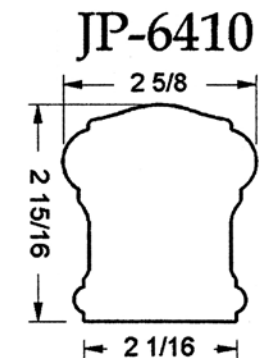
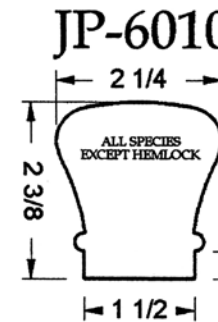
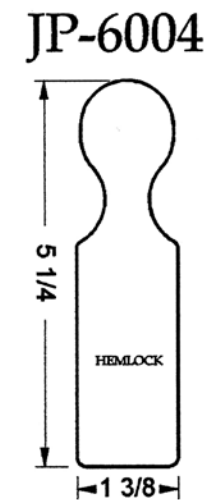
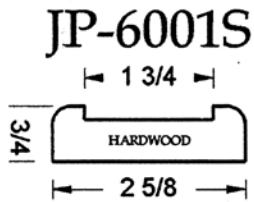
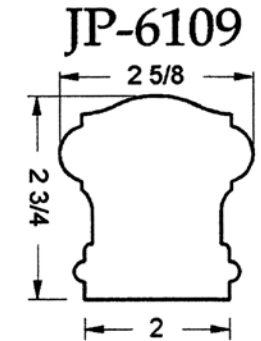
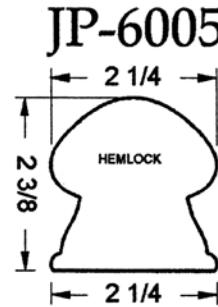
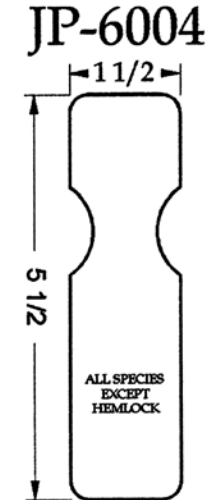
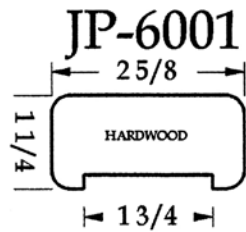
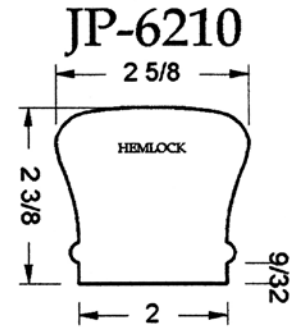
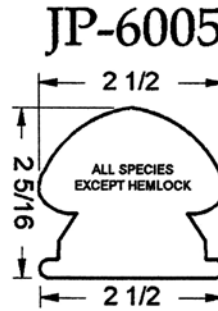
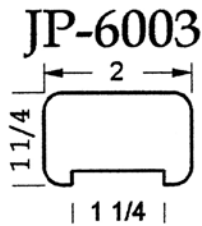
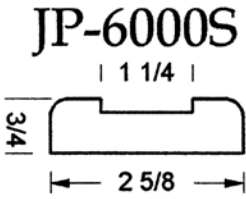
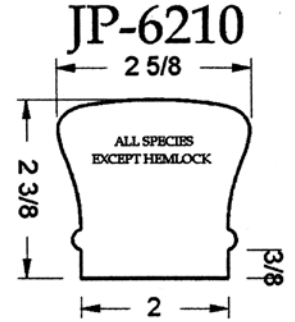
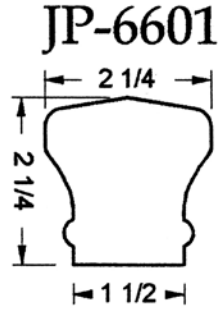
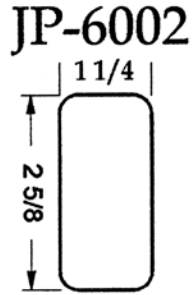
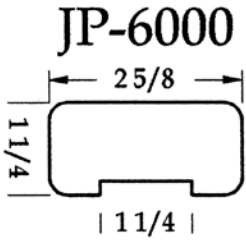

# Handrail Profiles

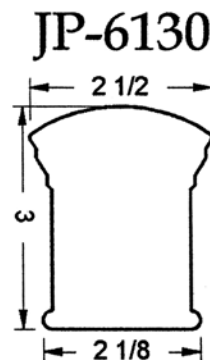
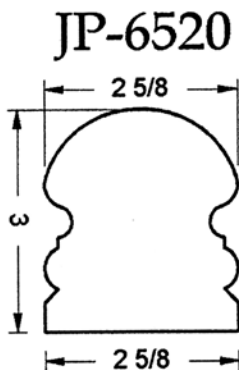
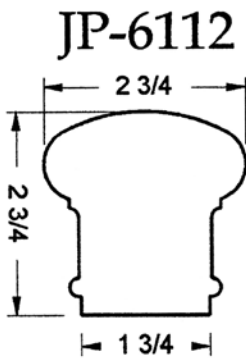
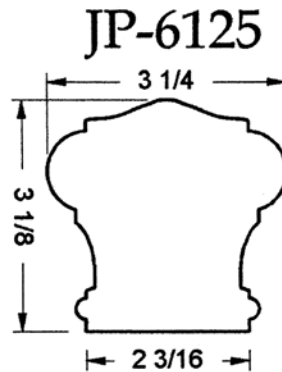
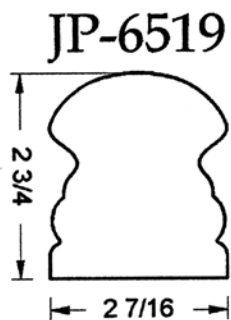
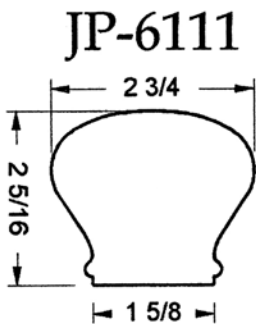
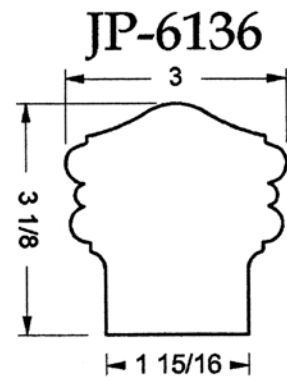
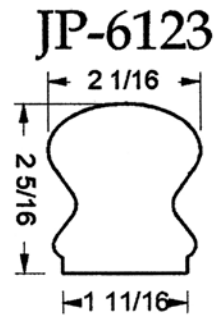
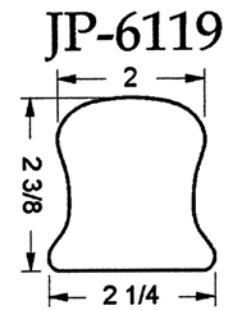
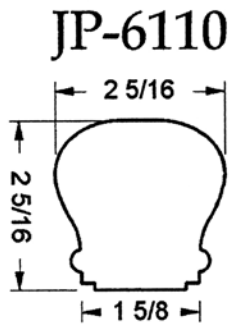
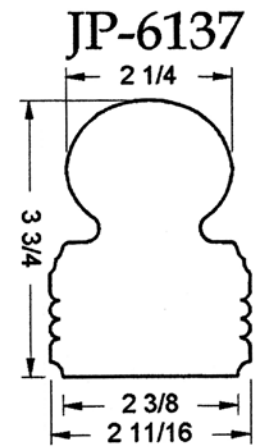
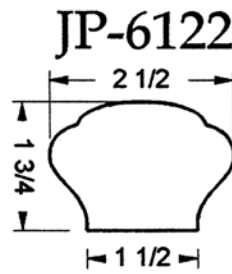
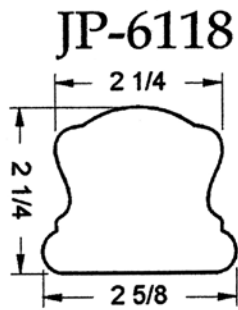
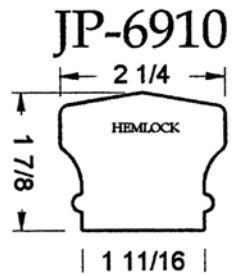
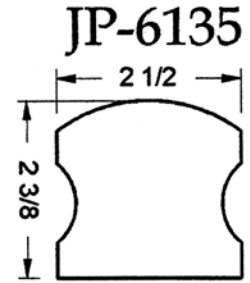
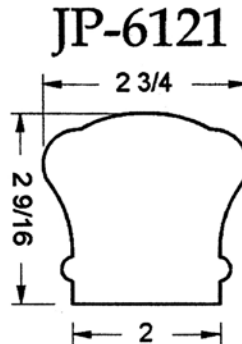
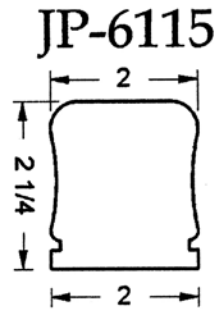
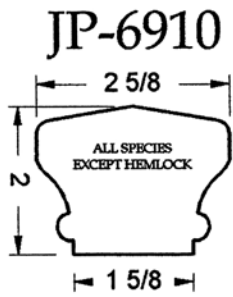





# Handrail & Shoerail Profiles

JP-6139

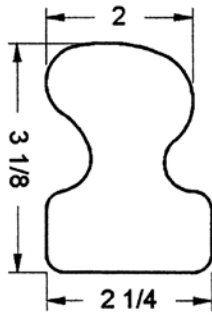

JP-6042

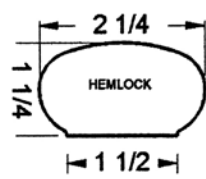

JP-6045

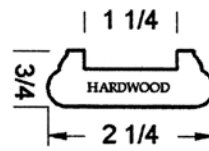

JP-6145

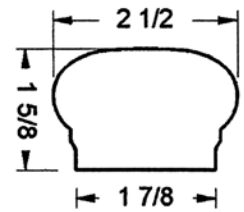

JP-6143

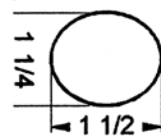

JP-6045

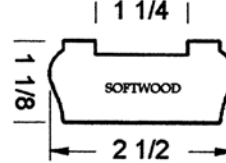

JP-6146

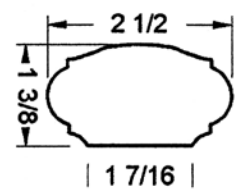

JP-6140

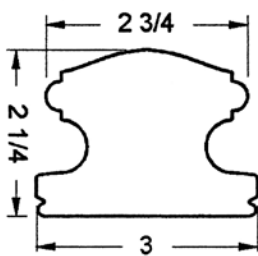

JP-6142

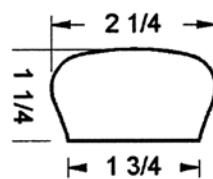

JP-6046

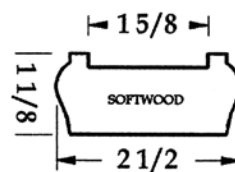

JP-6147

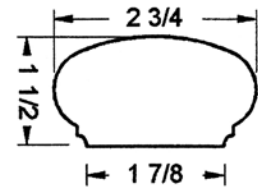

JP-6040

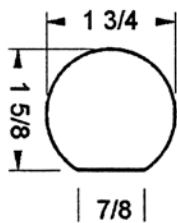

JP-6243

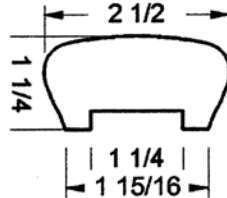

JP-6047

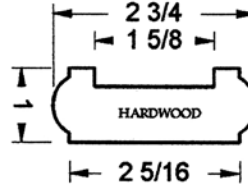

JP-6148

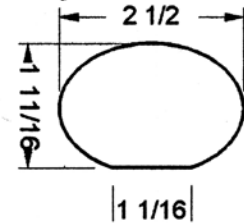

JP-6244

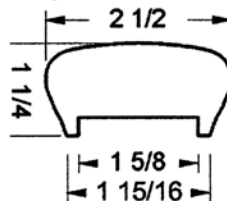

JP-6048

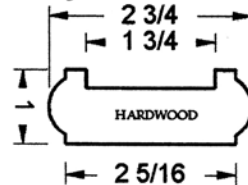

JP-6152

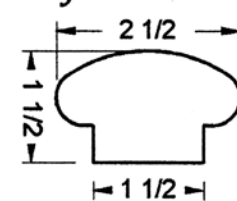

# Handrail Profiles

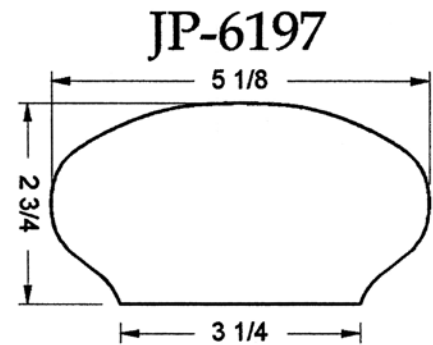
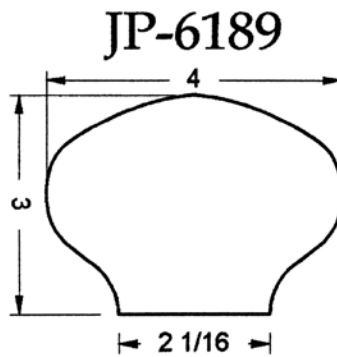
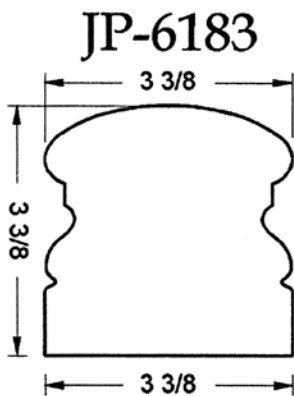
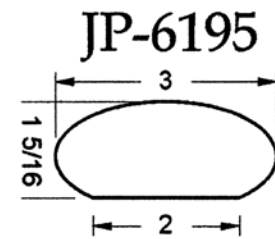
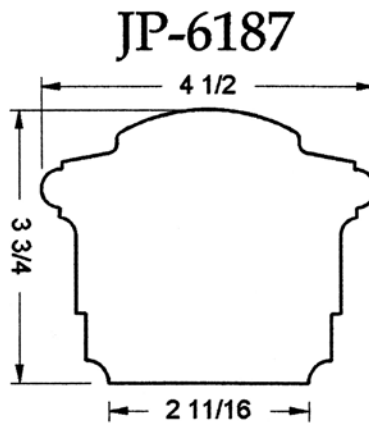
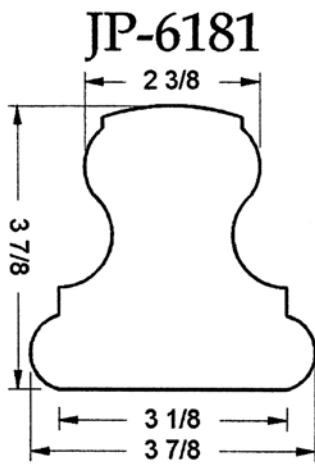

**JP-6198**

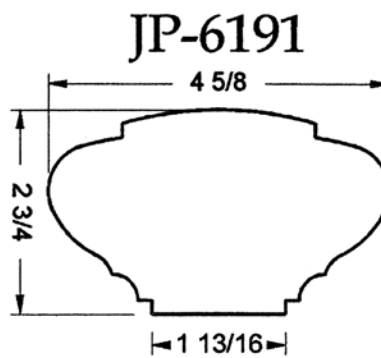
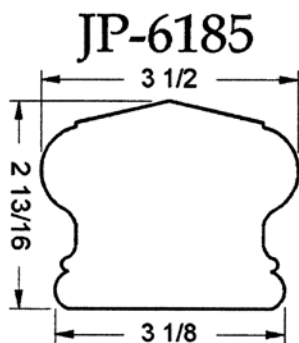
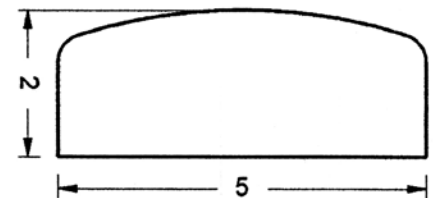

**JP-6199**

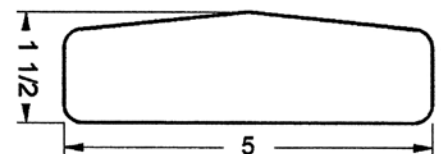



## Custom Mouldings

JP-9035

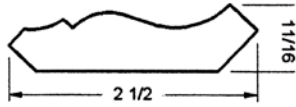

JP-9037

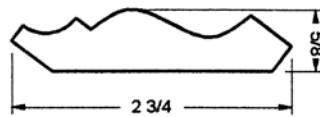

JP-9045

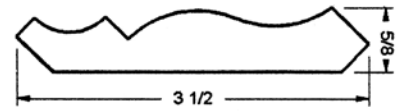

JP-9049

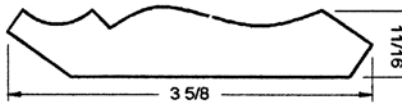

JP-9088

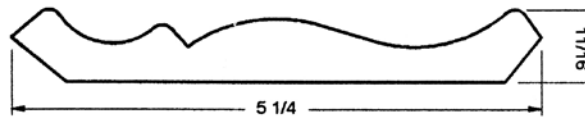

JP-9115



JP-9135

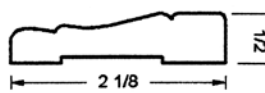

JP-9155

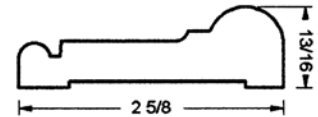

JP-9222

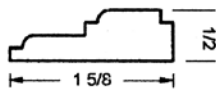

JP-9235

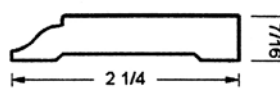

JP-9237

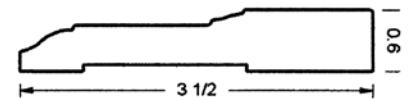

JP-9238

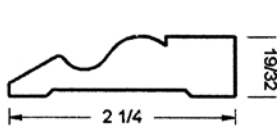

JP-9255



## Custom Mouldings

JP-9305



JP-9307

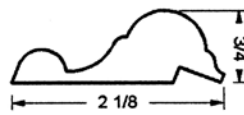

JP-9312

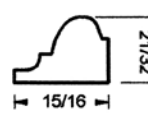

JP-9313

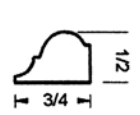

JP-9314

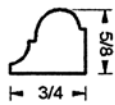

JP-9315

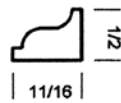

JP-9318



JP-9320

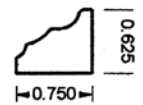

JP-9327

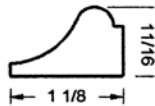

JP-9332

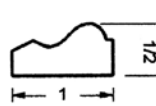

JP-9333

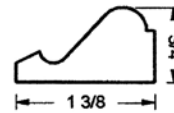

JP-9334

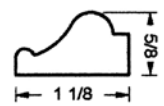

JP-9335

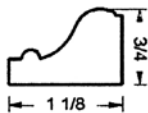

JP-9339

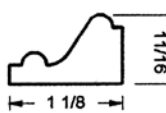

JP-9345

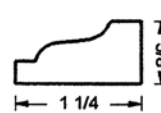

JP-9407

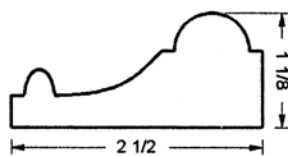

JP-9455

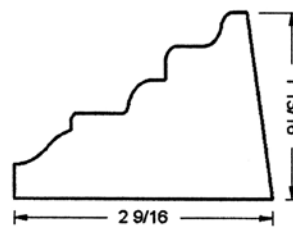



## Custom Mouldings

JP-9505

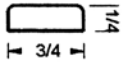

JP-9515



JP-9517

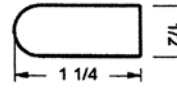

JP-9525



JP-9535

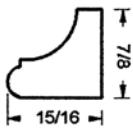

JP-9542

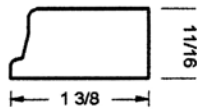

JP-9543



JP-9545



JP-9555

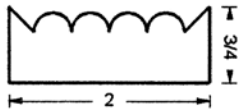

JP-9571

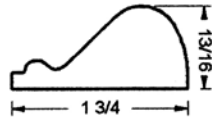

JP-9605

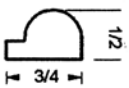

JP-9613

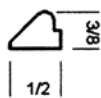

JP-9618

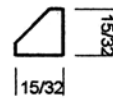

JP-9660



JP-9661

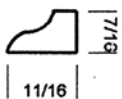

JP-9676

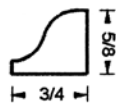

JP-9684

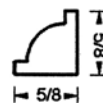

JP-9695

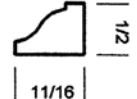

JP-9950



T & G V Joint

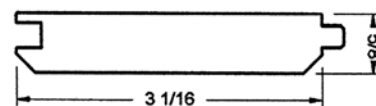

## Custom Mouldings

JP-9275

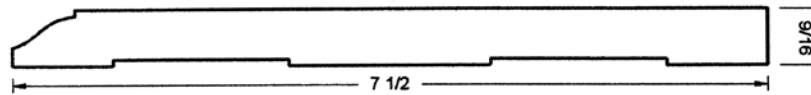

JP-9278

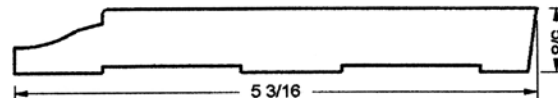

JP-9283

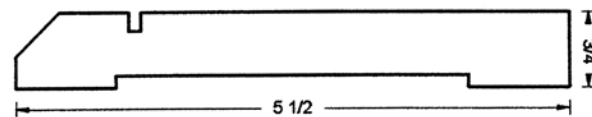

JP-9296

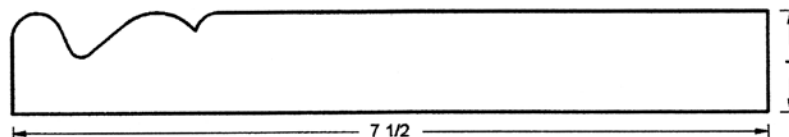

**Johnson Postman has the capability to manufacture custom moldings to your specifications in almost any species of wood.**



# Square Newels

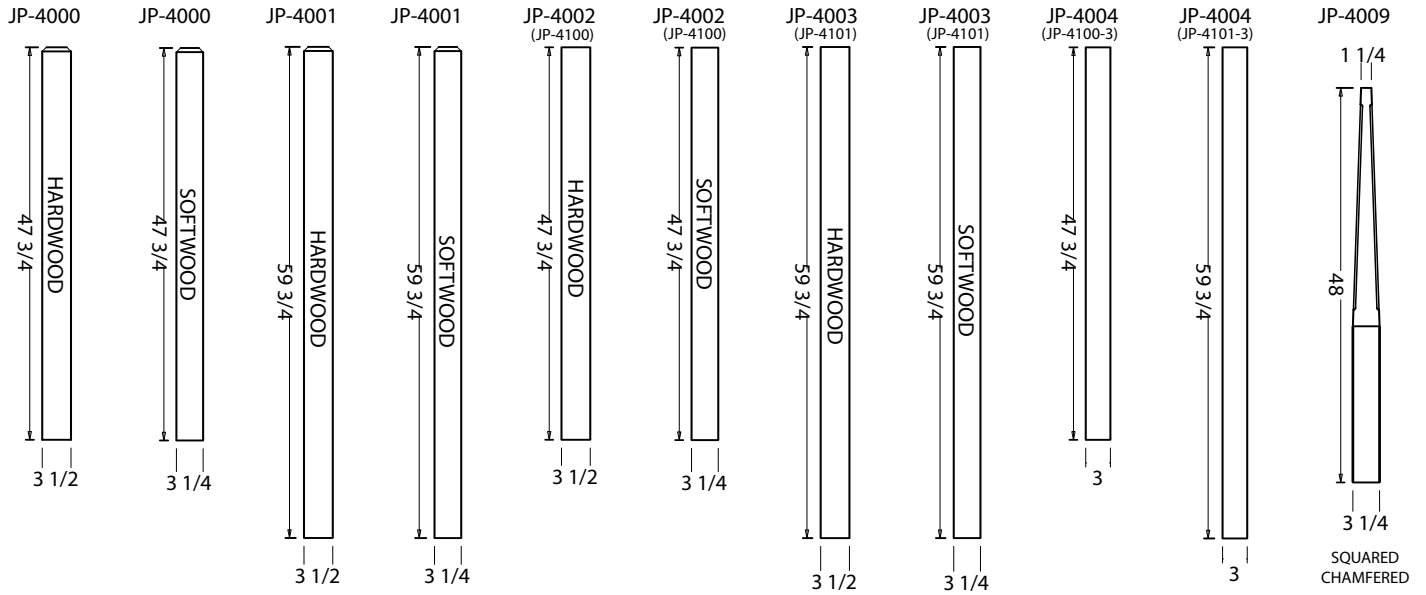

# Round Newels

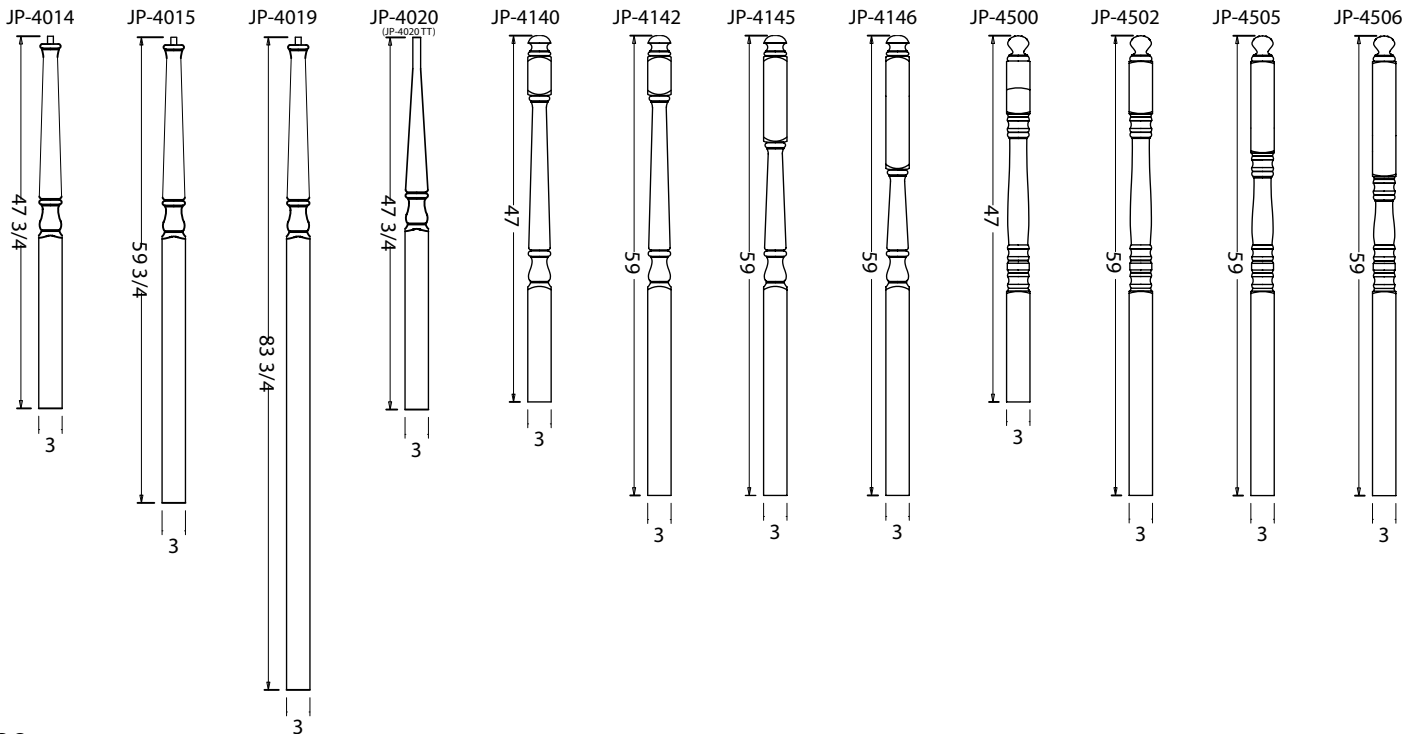



# Box Newels

## RECESSED PANELS

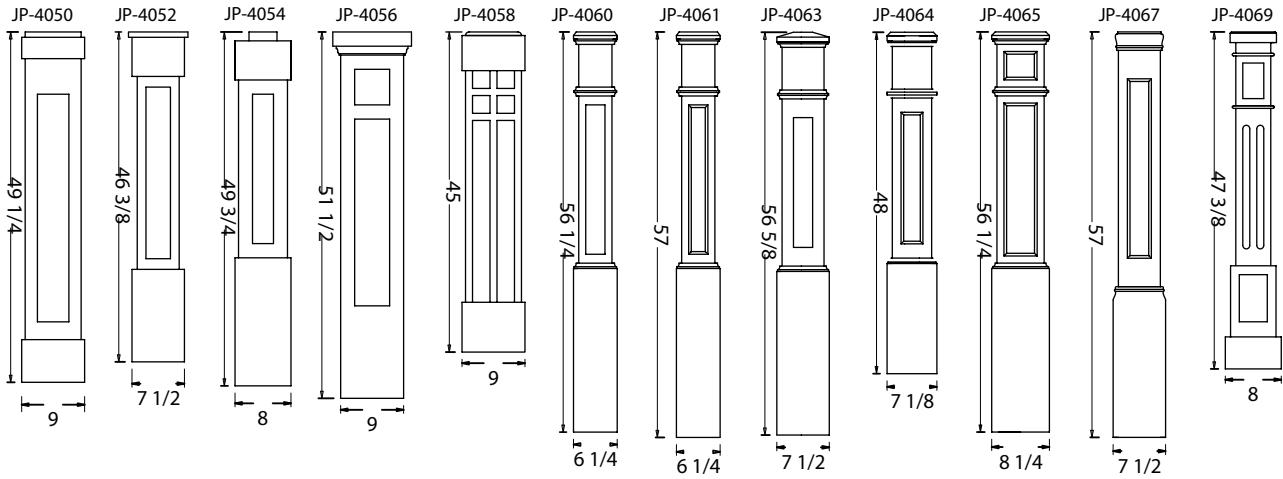

## RAISED PANELS

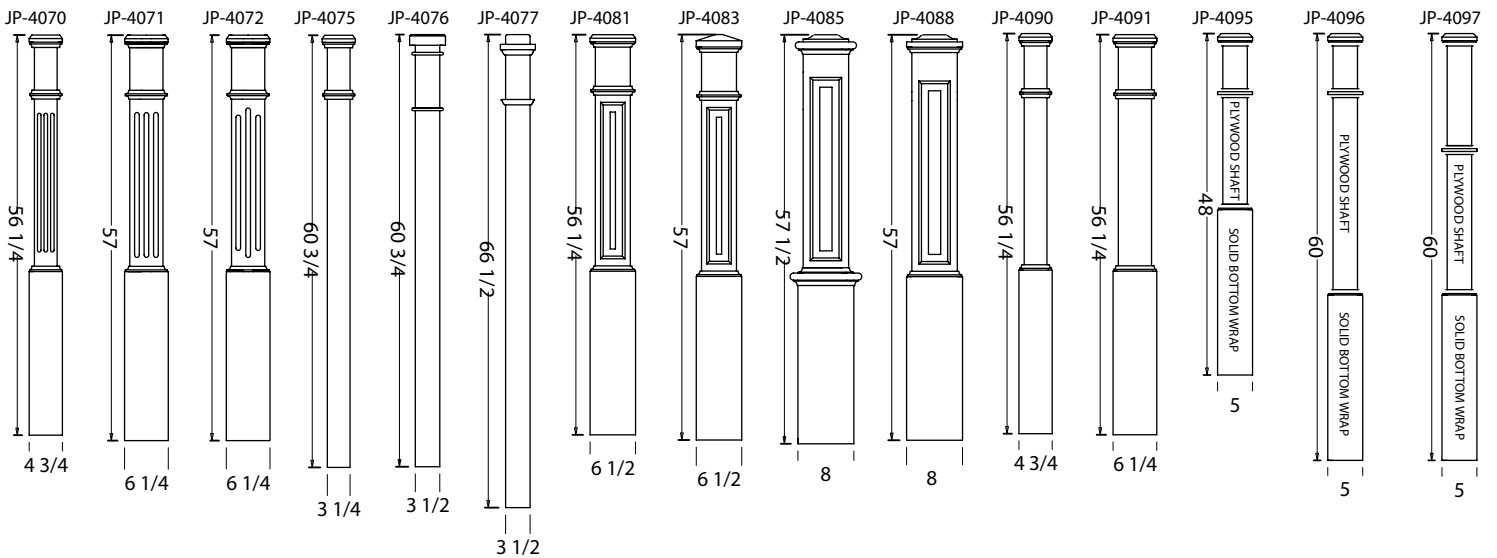





# Turned Newels

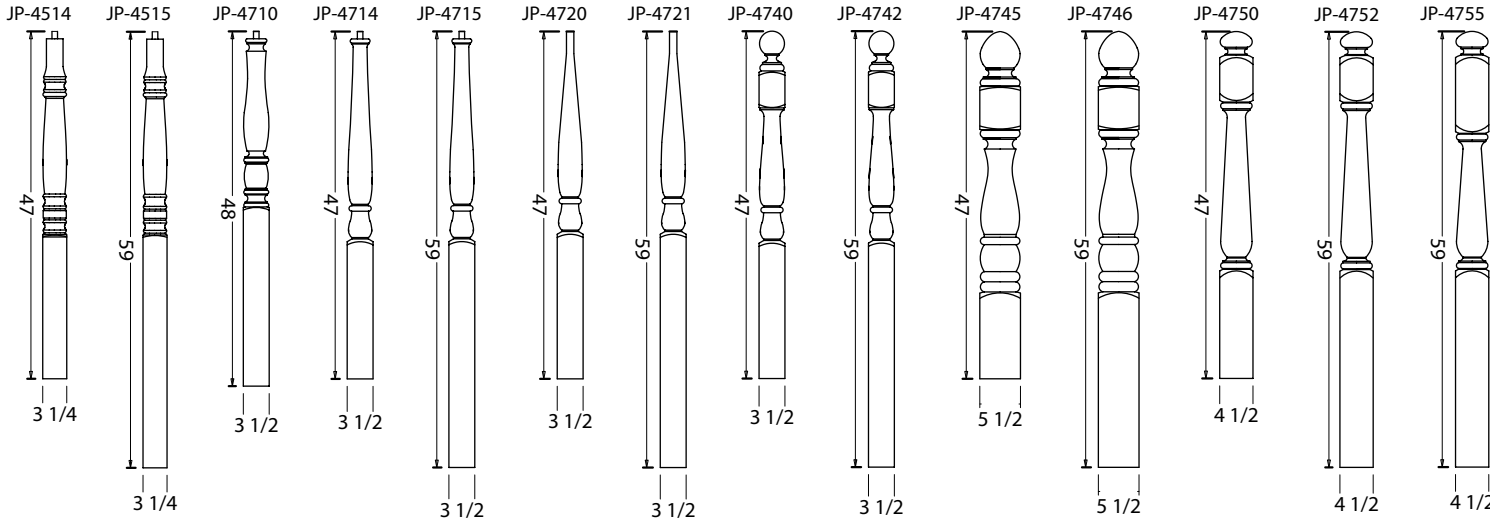

# Large Turnings

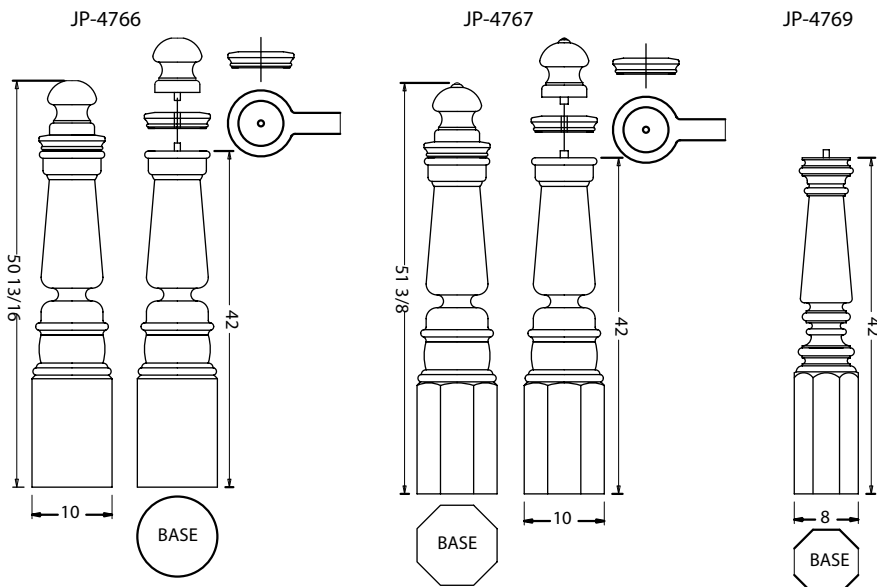

## Finials

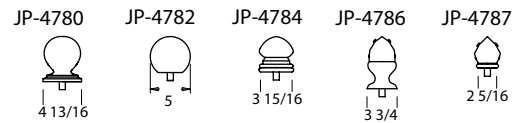

## Newel Caps

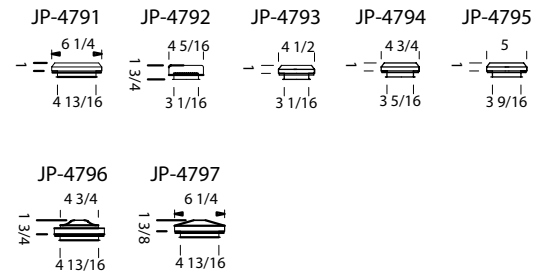



# Fitts Newels

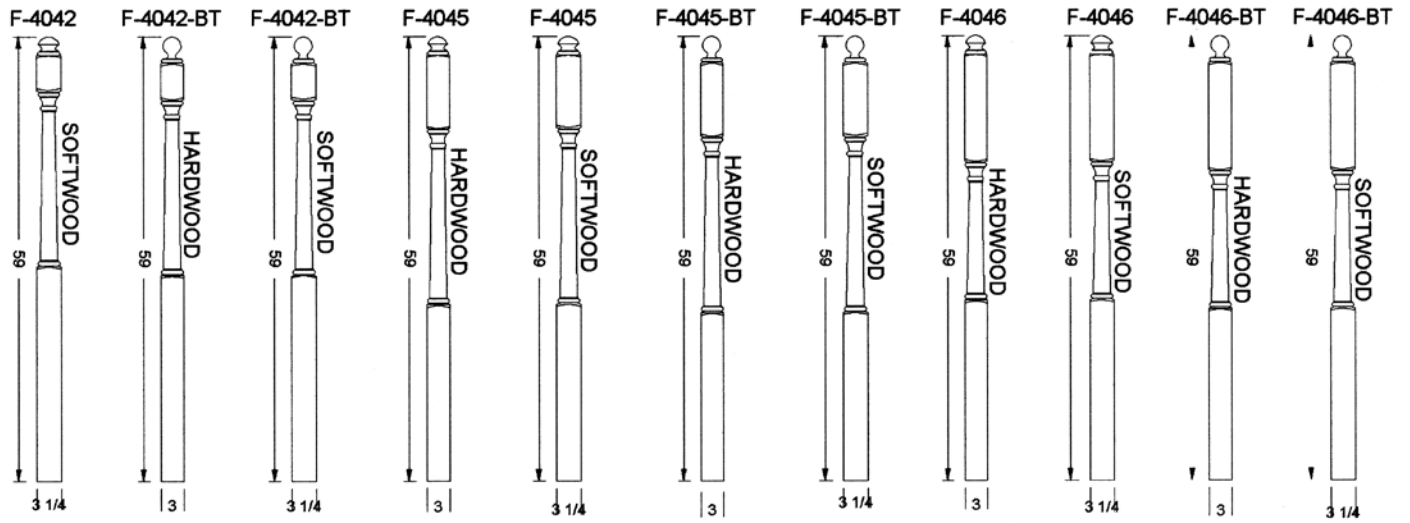
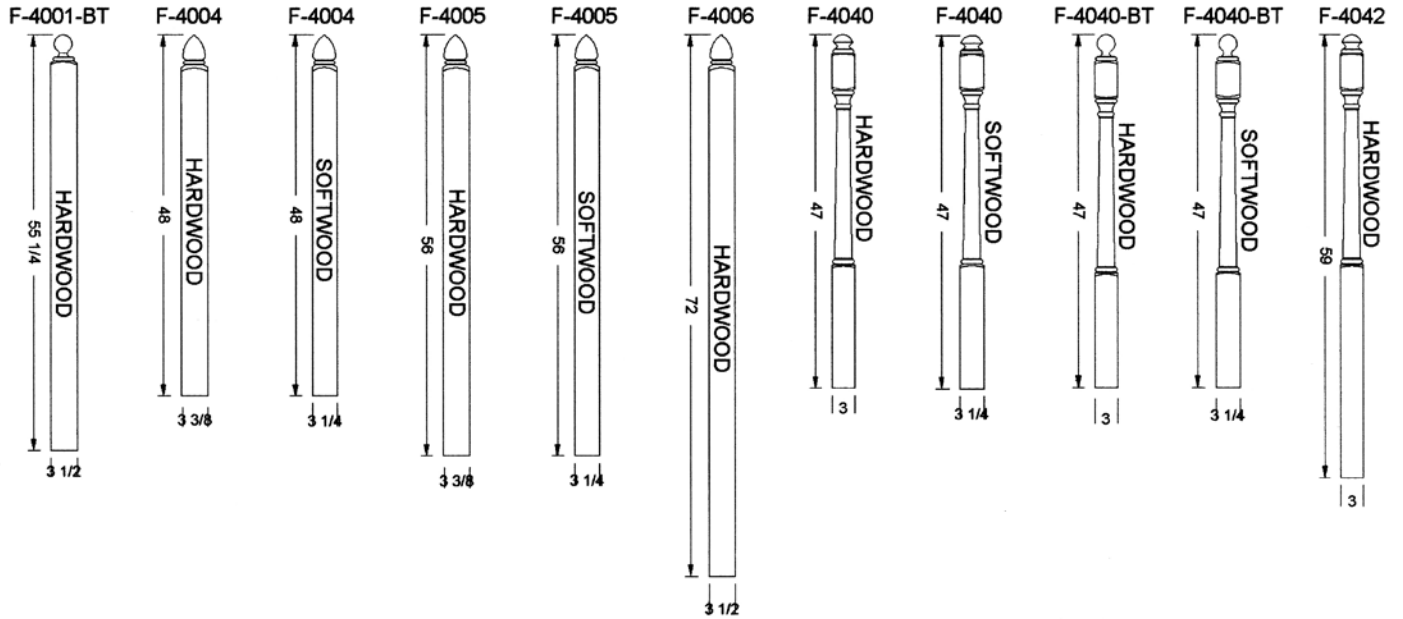



# Fitts Newels

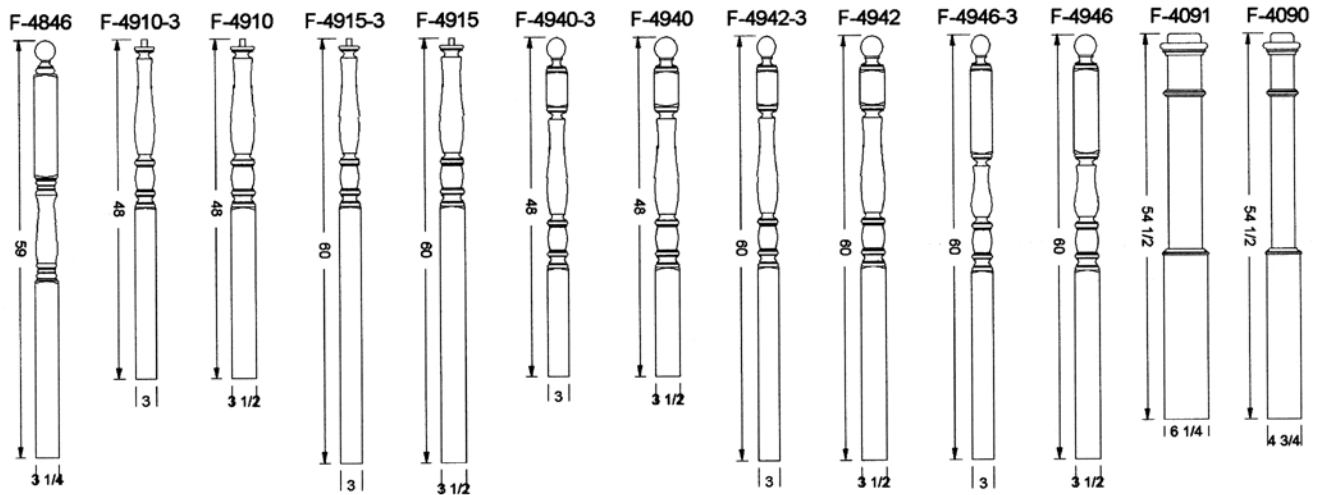
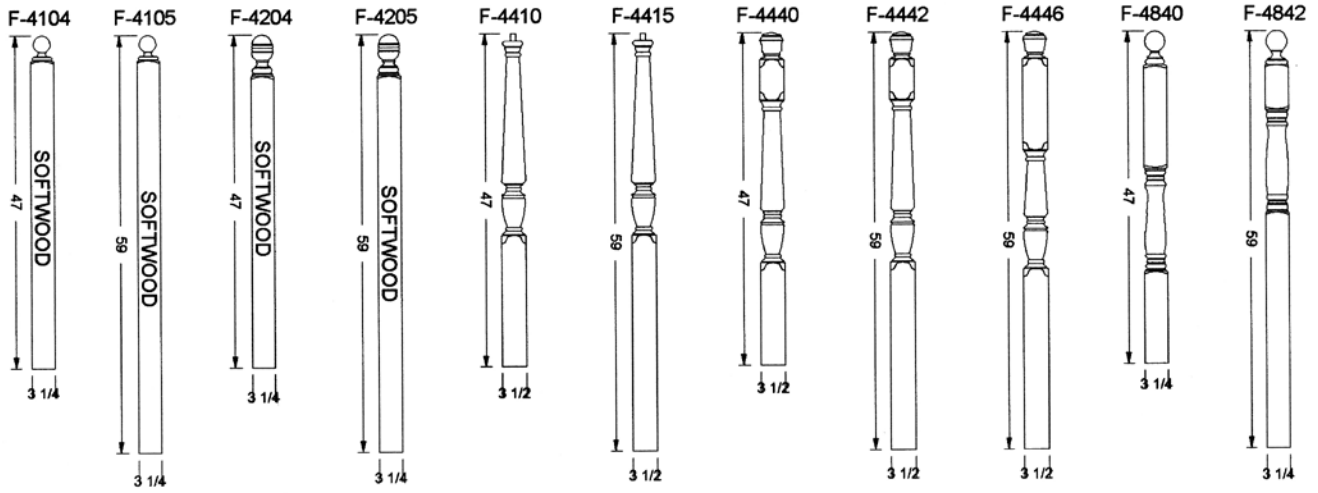



# Starting Steps

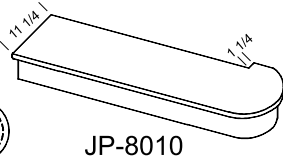
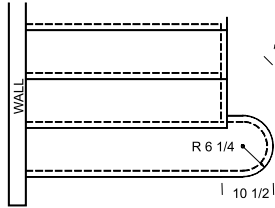

JP-8010

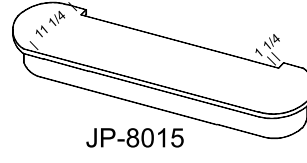

JP-8015

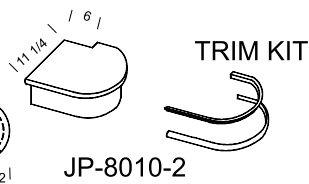
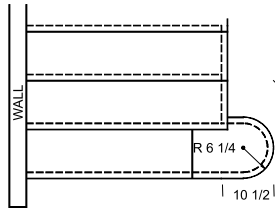
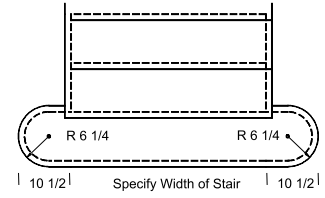

JP-8010-2

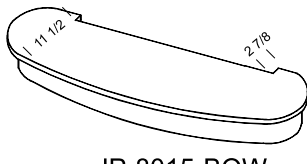

JP-8015-BOW

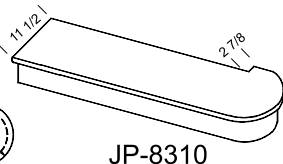
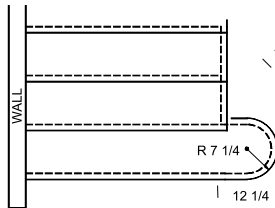
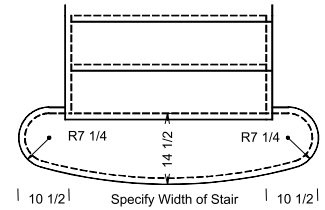

JP-8310

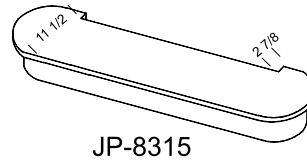

JP-8315

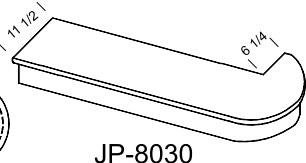
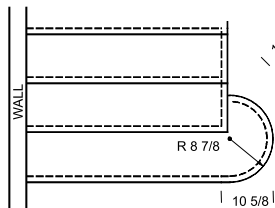
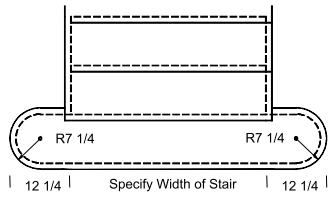

JP-8030

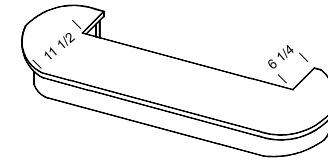

JP-8050

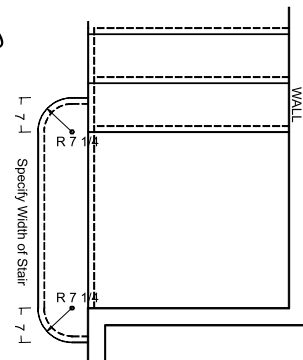
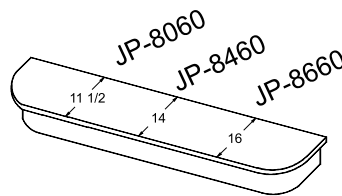
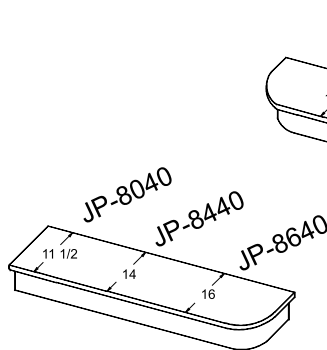
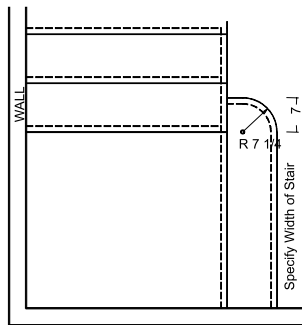
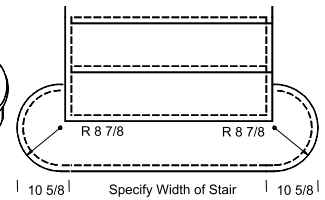



# Tread and Risers

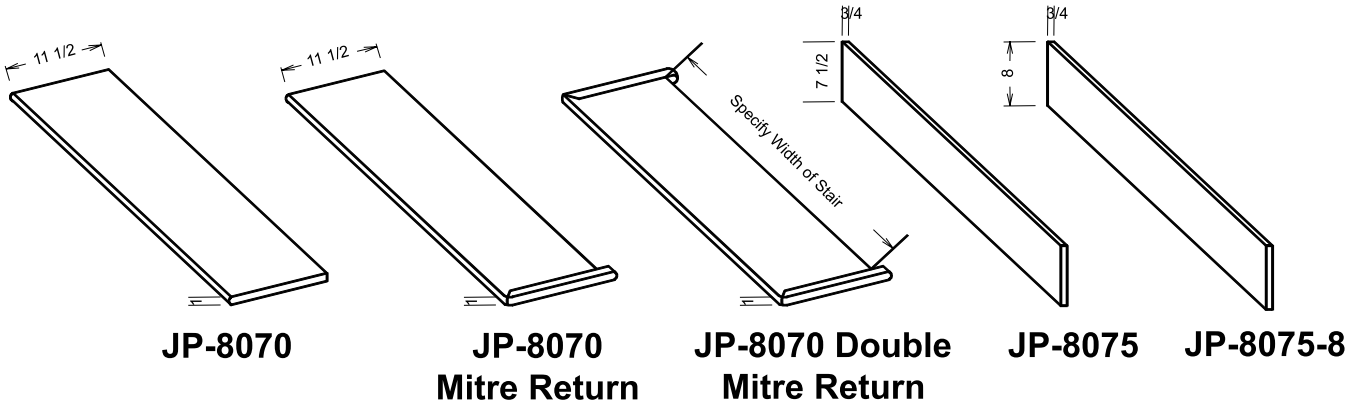

\* Specify Left or Right Hand when ordering Mitred Treads

Standard Tread & Riser Lengths:  
36" - 42" - 48" - 60" - 72" - 96"

# False Tread and Risers • Wall Caps

**4-1/2" Width**

(Left Hand Shown)

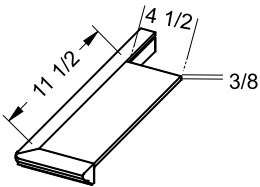

JP-8071

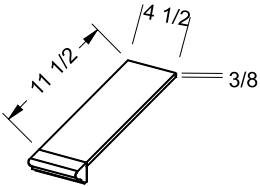

JP-8072

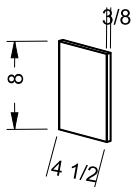

JP-8076

**6-1/2" Width**

(Left Hand Shown)

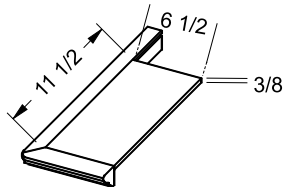

JP-8071 6.5

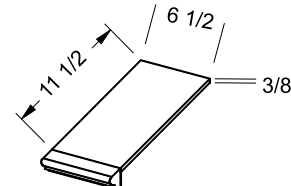

JP-8072 6.5

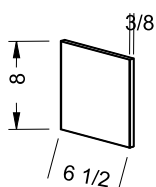

JP-8076 6.5

**Reversible**

Available in 4-1/2" & 6-1/2" Width

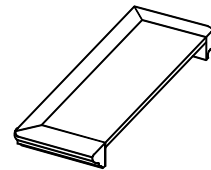

JP-8071-V  
JP-8071 6.5-V

\* Available in Oak & Maple

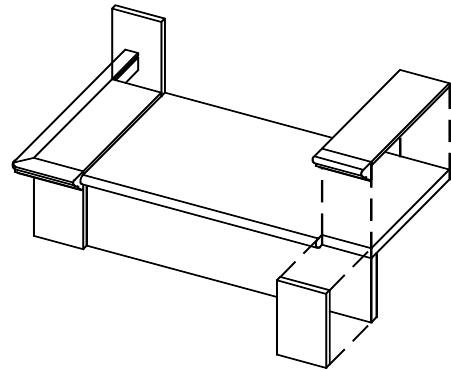

Specify Left Hand, Right Hand, or Reversible when ordering False Treads

# Accessories

## Landing Tread

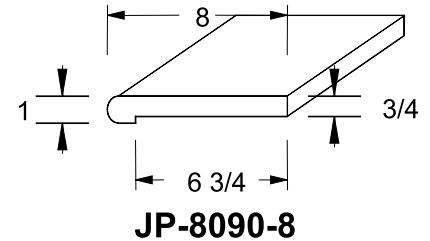
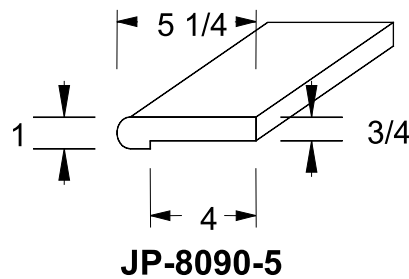
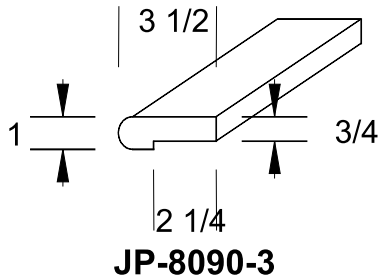

## Stair Mouldings

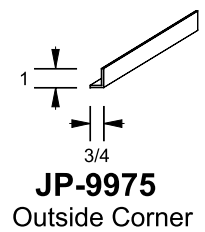
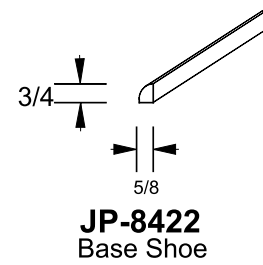
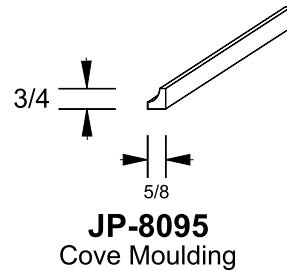
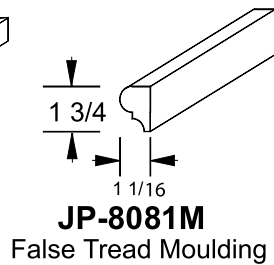
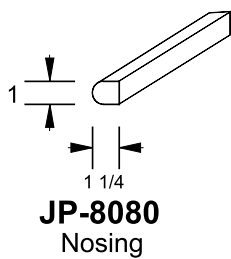

## Skirt & Trim Boards

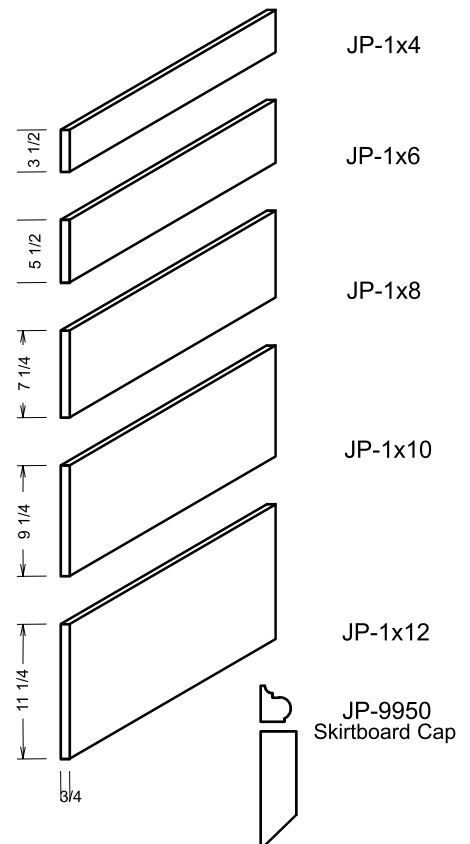

## Rosettes & Brackets

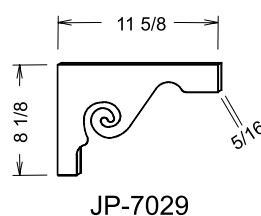
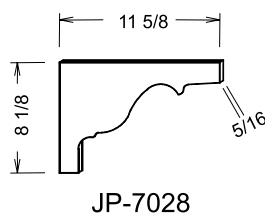
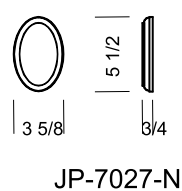
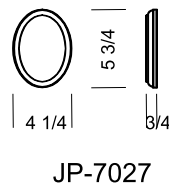
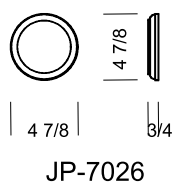



# Tools and Hardware

## Installation Tools

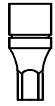

**JP-332**  
Rail Bolt  
Runner

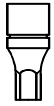

**JP-333**  
Baluster Bolt  
Runner



**JP-334**  
Screw  
Runner

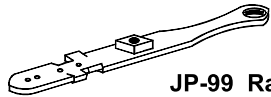

**JP-99** Rail Bolt Wrench

## Wall Rail Brackets

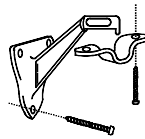

**JP-3002**  
Plated Wall  
Bracket

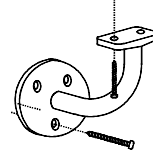

**JP-3027**  
Wall Bracket

*\*Bright Brass  
Brushed Chrome  
Bright Chrome  
Oil Rubbed Bronze  
Antique Brass  
Antique Nickel  
Flat Black  
Satin Black*

## Newel Post Fastening Hardware

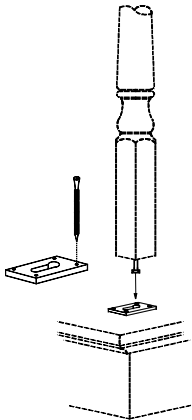

**JP-3005**  
Keylock

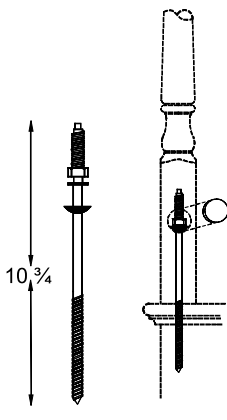

**JP-3008**  
Sure-Tite

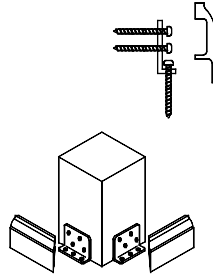

**JP-319**  
L-Anchor

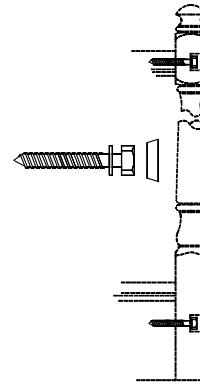

**JP-378**  
Newel & Rail  
Fastener

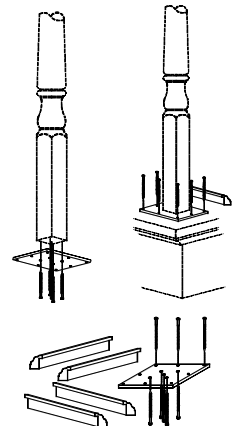

**JP-306**  
Mounting Plate

## Handrail to Newel Fasteners



**JP-375**  
Flush  
Mount Kit

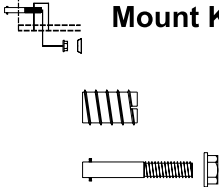

**JP-Mini**  
Lock

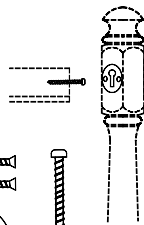

**JP-376-1**  
Dowel Screw

## Baluster Fasteners

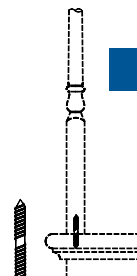

**JP-Pin**  
Wood Dowel

## Bolts, Screws & Plugs

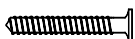

**JP-SRS**  
2-1/2" Screws



**JP-3000**  
1" WoodPlug

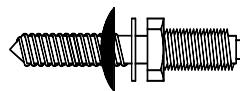

**JP-3001**  
Rail Bolt

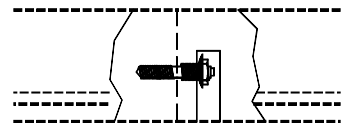

## Newels

3/4" Dia. Pin Top (Typical all 1-1/8" Sq. Newels shown)



FI411-48 Bordeaux

FI415-48 Bordeaux

FI412-48 Provance

FI414-48 Tavistock

■ 1-1/8" Sq. Base (Typical all Newels shown)



FI3200-NZ

FI3200-EF

FI3200

FI3200-NZ Nozzle

FI3200-EF Two Part Epoxy

FI3200 Epoxy gun

## Shoes / Knuckles for Square Balusters



FI3101 1/2 inch shoe  
FI3101-2 9/16 inch shoe



FI3104 1/2 inch shoe  
FI3104-2 9/16 inch shoe



FI3102 1/2 inch pitch shoe  
FI3102-2 9/16 inch pitch shoe



FI3103 adjustable  
1/2 inch knuckle

## Shoes for Round Balusters



FI3101-5 1/2"  
Round Shoe



FI3102-5 1/2"  
Round Pitch Shoe



FI3104 1/2"  
Round Shoe  
w/screws



FI3400 Newel attachment and

## Six Elegant Finish Styles to Choose From



Black

Black Satin

Silver Black

Antique Bronze

Antique Nickel

Rubbed Bronze





# Iron Balusters

## 1/2 inch Balusters

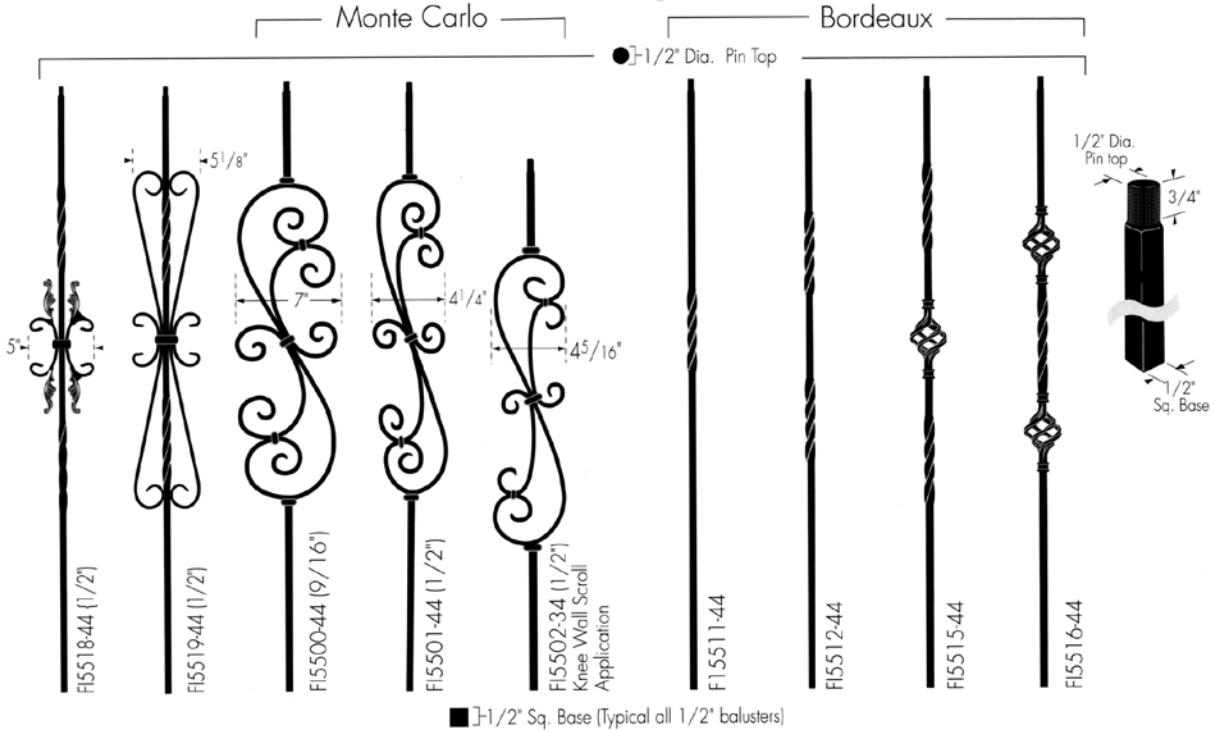

For 1/2" Balusters use:

- F13101 Shoe
- F13102 Pitch Shoe for Knee Wall Installation
- F13104 Shoe w/screws
- F13103 Adjustable Knuckle

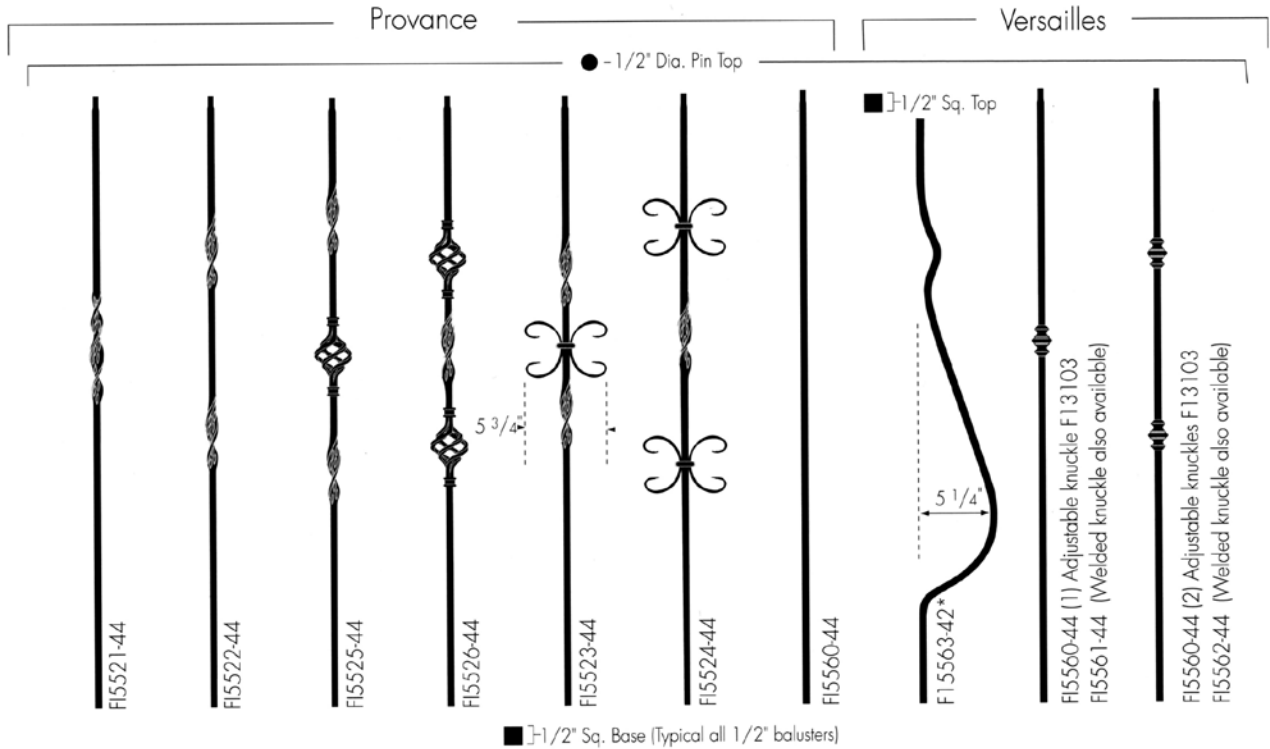

# Iron Balusters

## 1/2 inch Balusters

### Burgundy Round

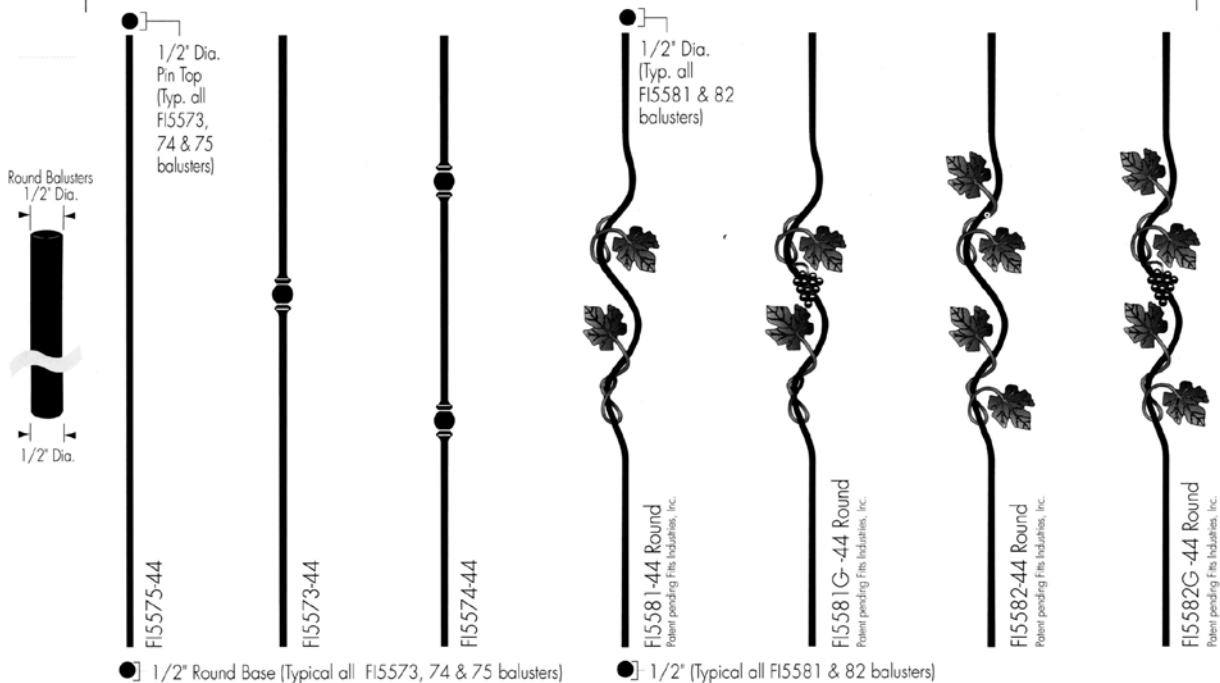

● 1/2" Round Base (Typical all FI5573, 74 & 75 balusters)

■ 1/2" (Typical all FI5581 & 82 balusters)

For 1/2" Round Balusters use:

For 9/16" Balusters use:

FI3101-5 (1/2")  
Round Shoe



FI3102-5 (1/2")  
Round Shoe



FI3104-5 (1/2")  
Round Shoe  
w/screws



FI3101-2  
9/16" Shoe



FI3102-2  
9/16" Shoe



FI3104-2  
9/16" Shoe  
w/screws



## 9/16 inch Balusters

### Tavistock

### Burgundy

### Phoenix

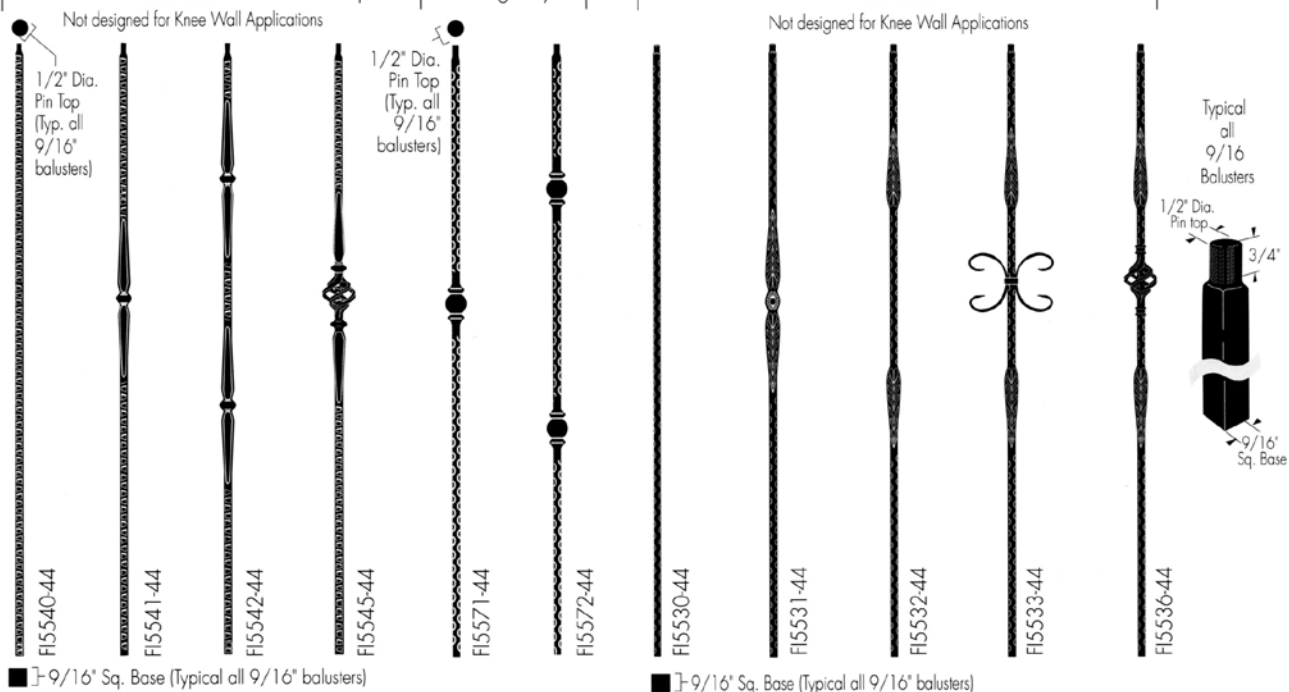

■ 9/16" Sq. Base (Typical all 9/16" balusters)

■ 9/16" Sq. Base (Typical all 9/16" balusters)



### Oak Newel Posts

### 3" Square

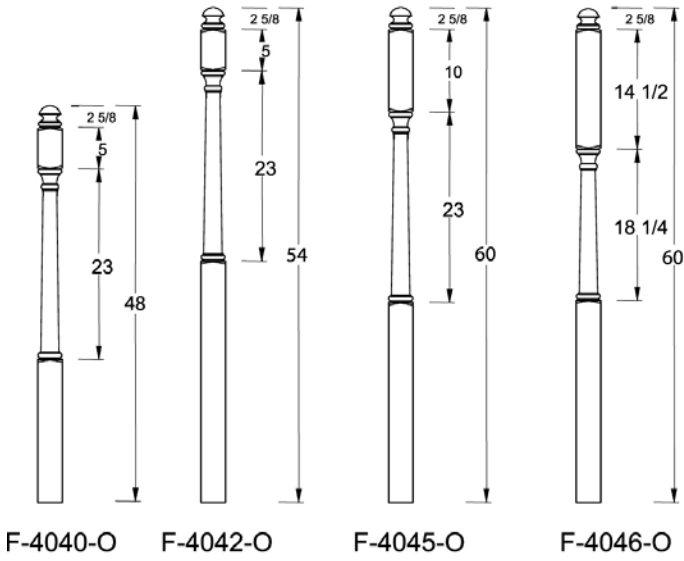

### 3" Square

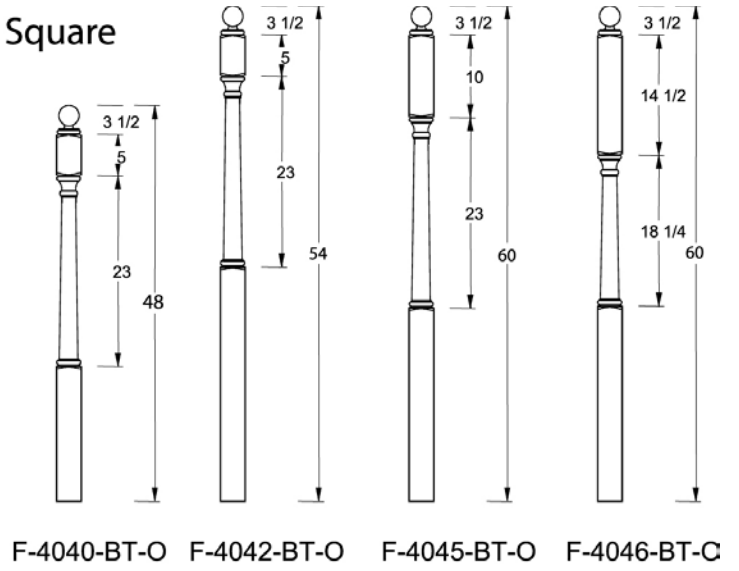

### 3 1/2" Square

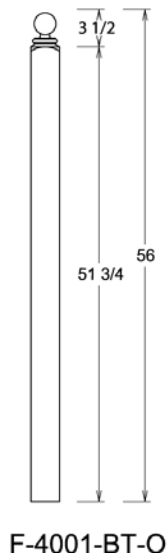

### 3 1/2" Square

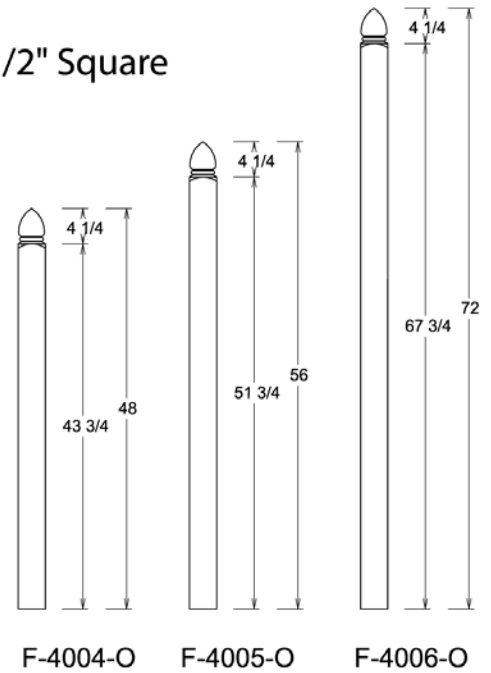

*Fitt*

Oak Balusters

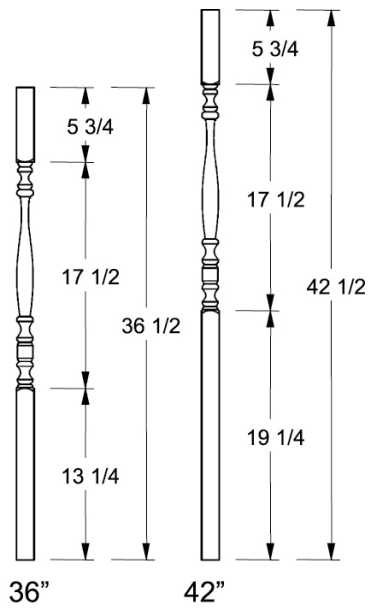

**F-5105-O**  
1-1/4" Square

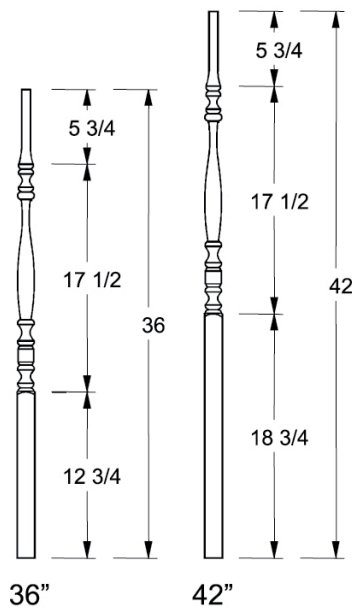

**F-5610-O**  
1-1/4" Square





## Hemlock Newel Posts

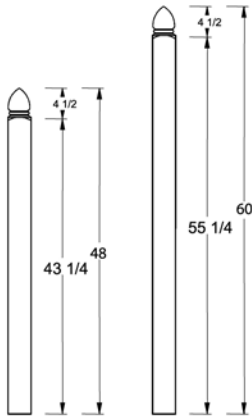

F-4004-H

F-4005-H

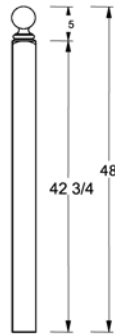

F-4104-H

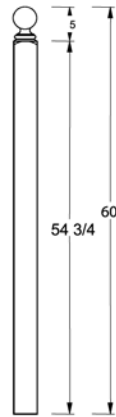

F-4105-H

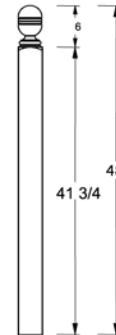

F-4204-H

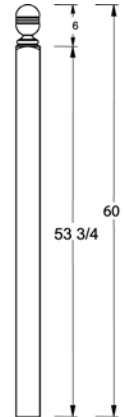

F-4205-H

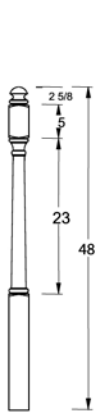

F-4040-H



F-4042-H

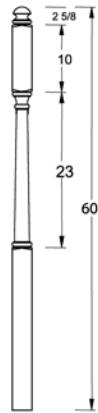

F-4045-H

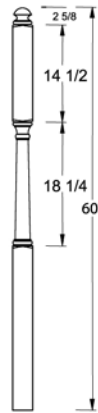

F-4046-H

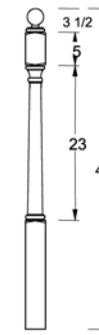

F-4040-BT-H



F-4042-BT-H



F-4045-BT-H

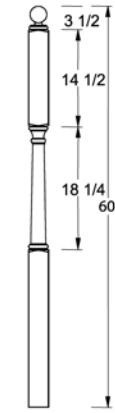

F-4046-BT-H

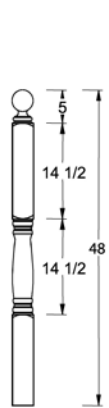

F-4840-H

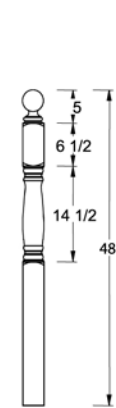

F-4842-48-H



F-4842-H

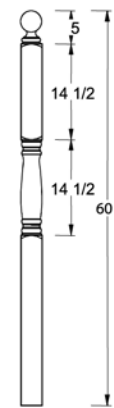

F-4846-H

All newels are 3 1/4" square

# Fitline

## Hemlock Balusters

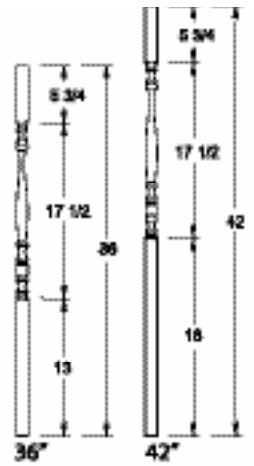

**F-5105-H** 1-1/4" Square

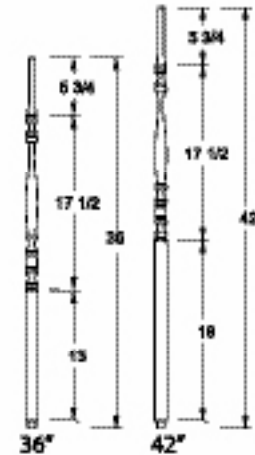

**F-5610-H** 1-1/4" Square

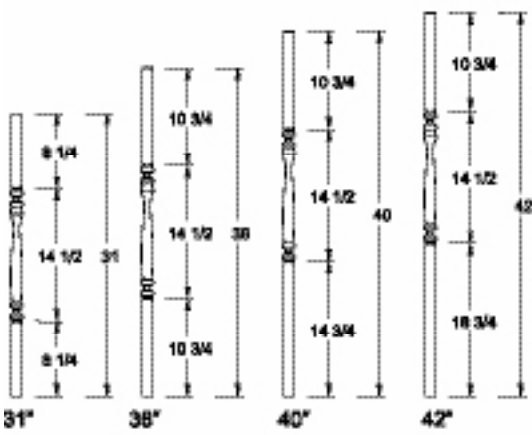

**F-5801-H**  
1-1/4" Square

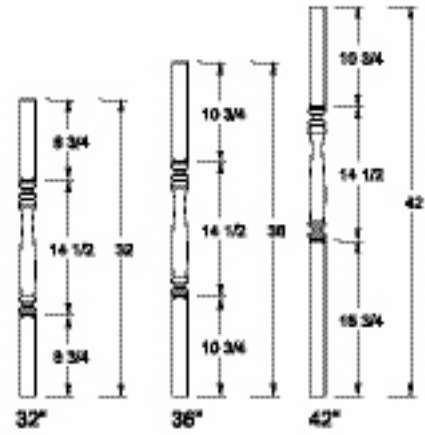

**F-5802-H**  
1-5/8" Square

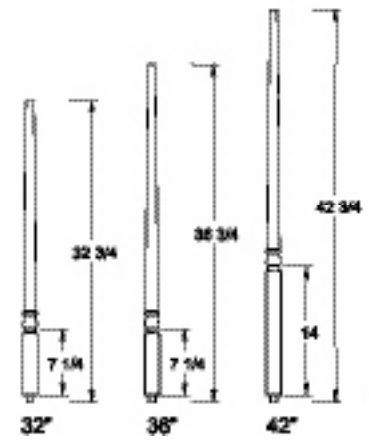

**F-5315-H**  
1-5/8" Square



# Sheraton Hardwood



## Newel Posts

3 1/2" square

### Fluted

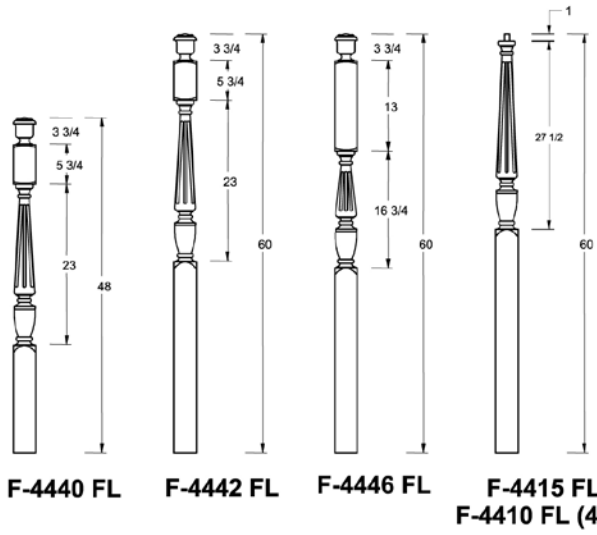

### Twist

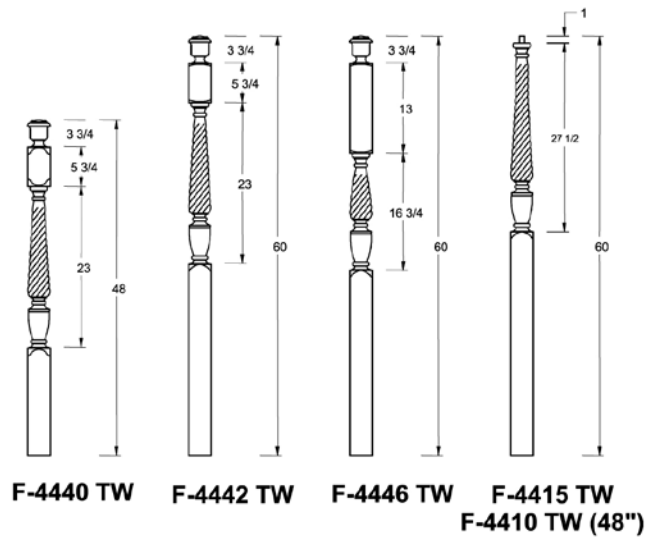

### Plain

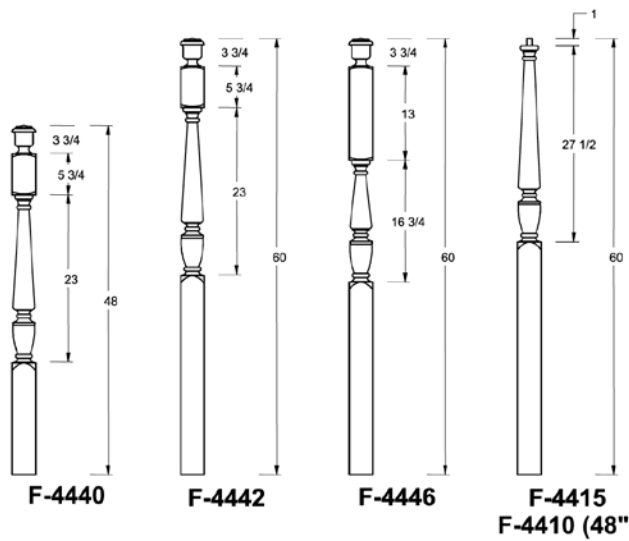



## Balusters

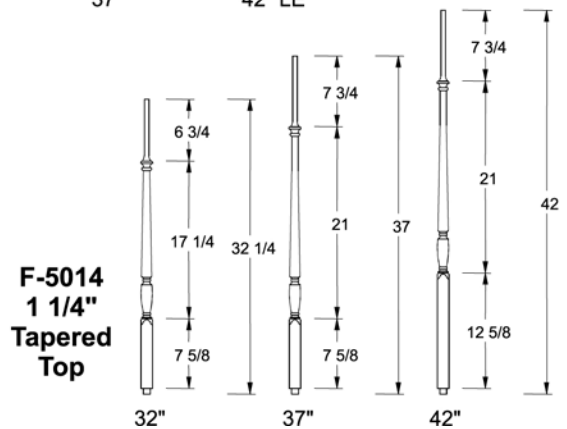
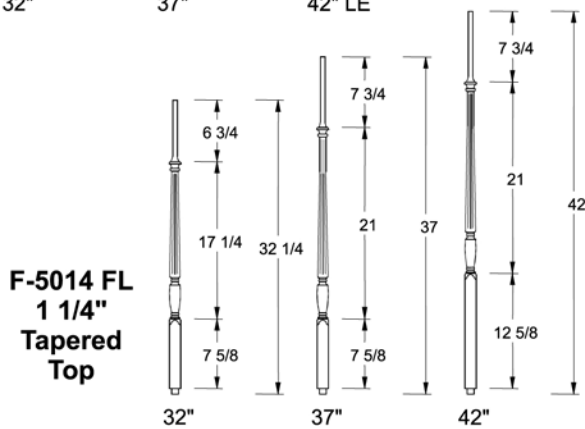
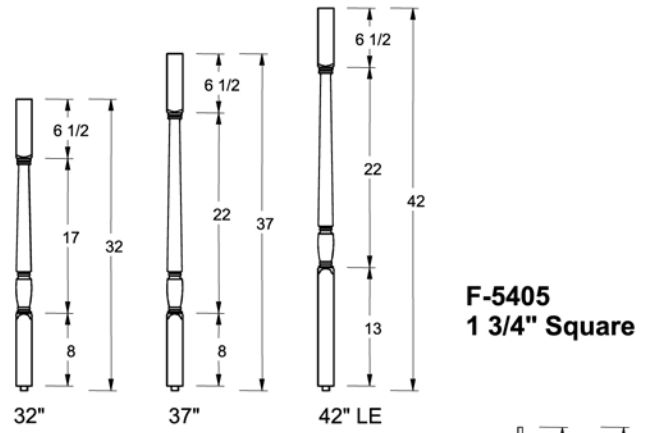
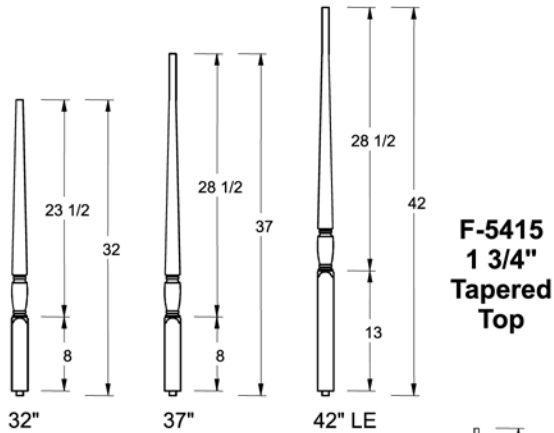
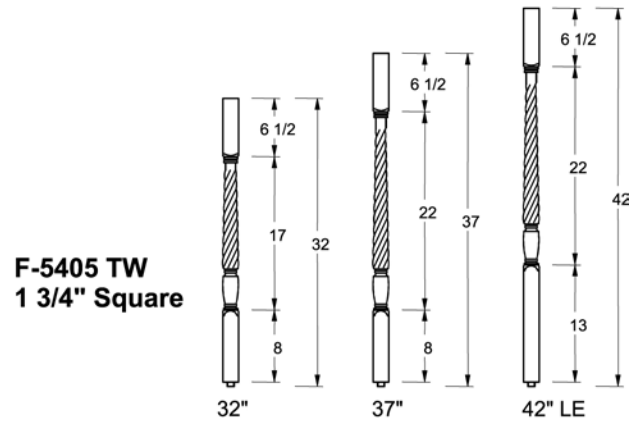
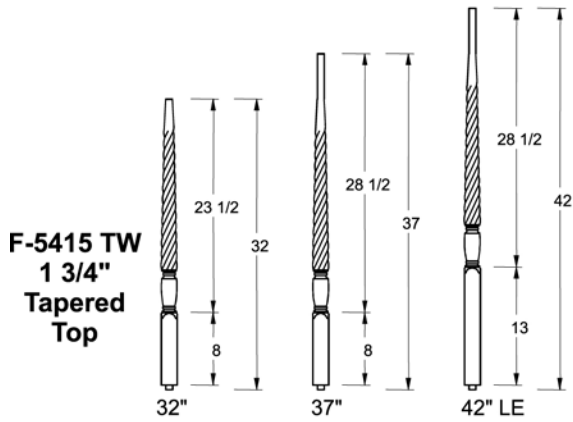
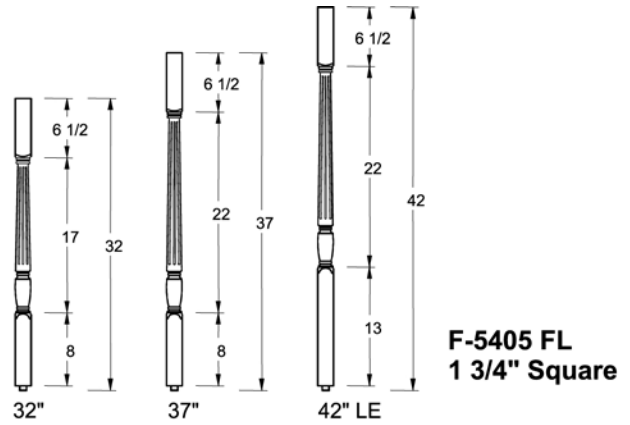
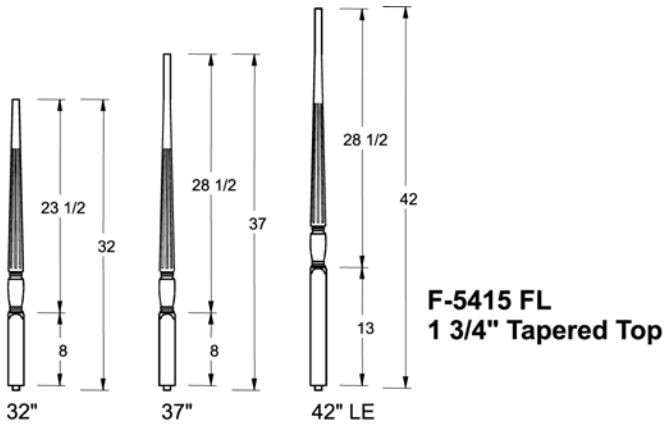





## Newel Posts

3" and 3 1/2" square

### Plain

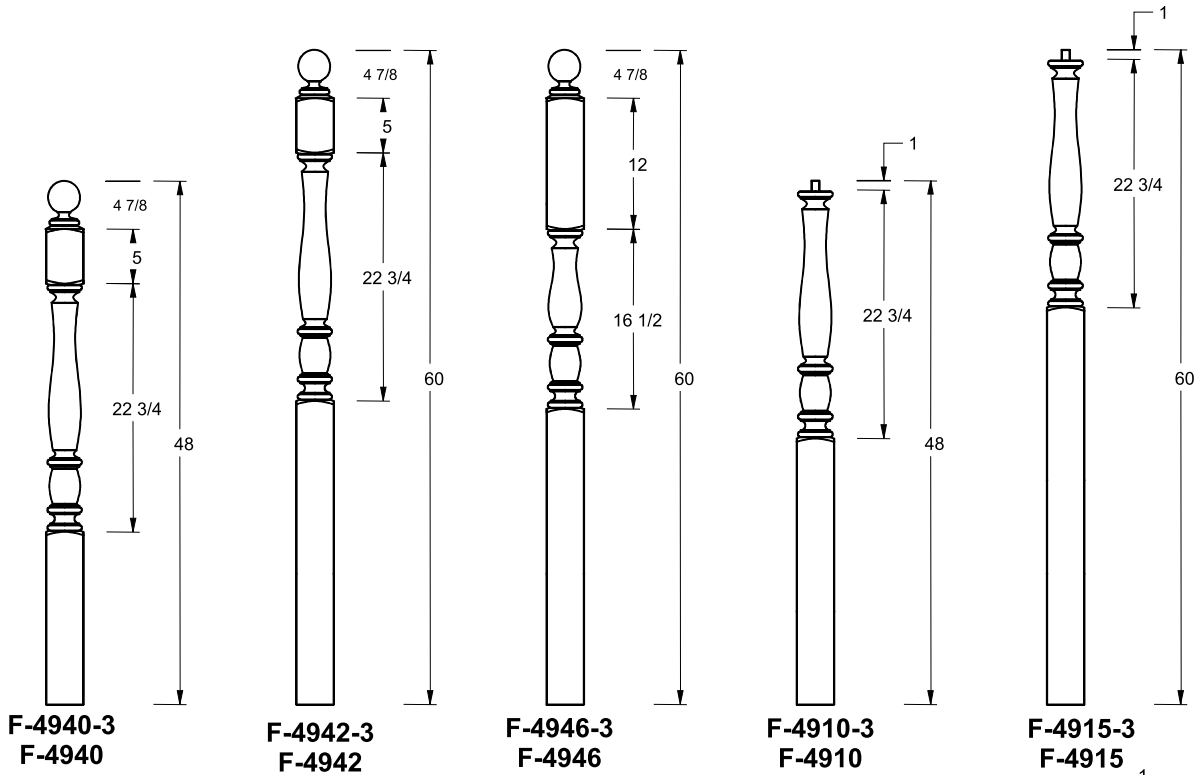

### Fluted

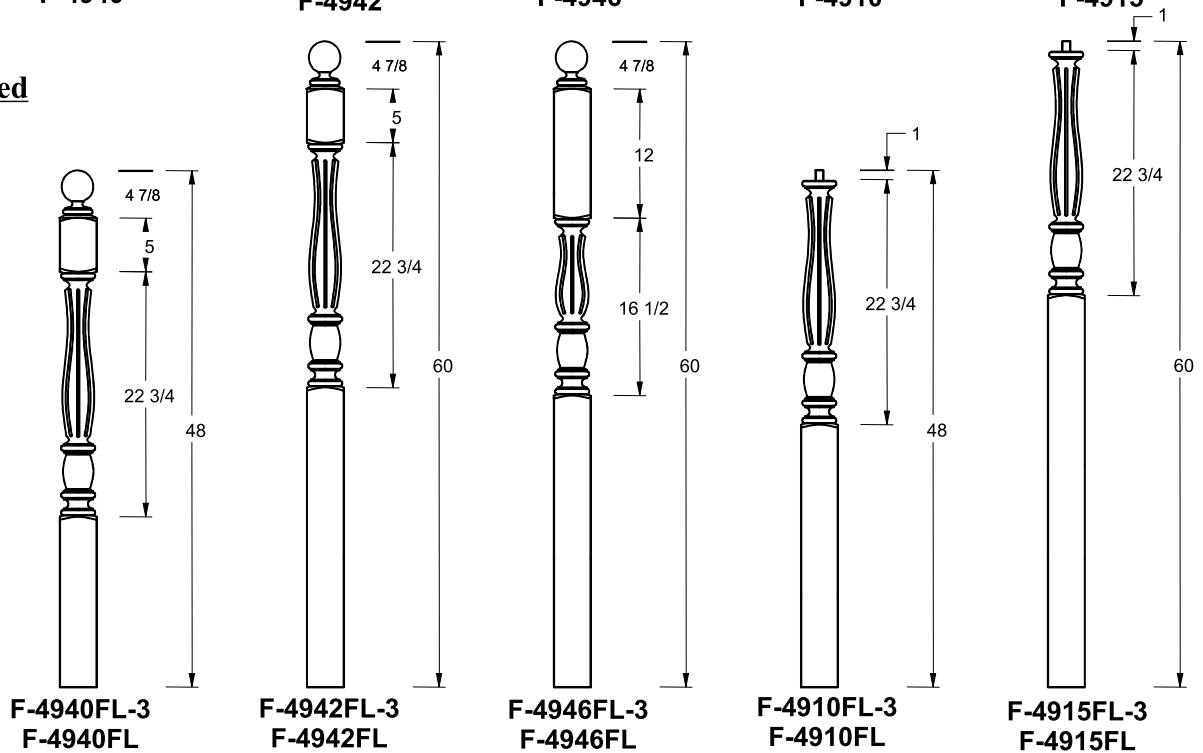



## Balusters

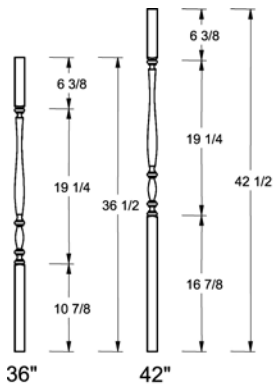

**F-5109**  
1 1/4" Square

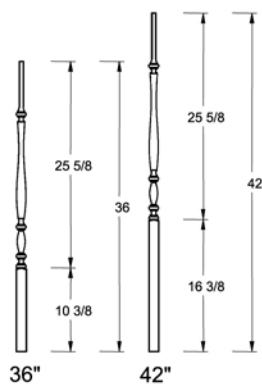

**F-5019**  
1 1/4" Tapered Top

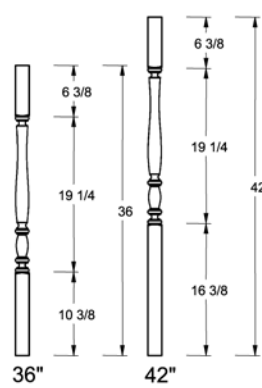

**F-5905**  
1 3/4" Square

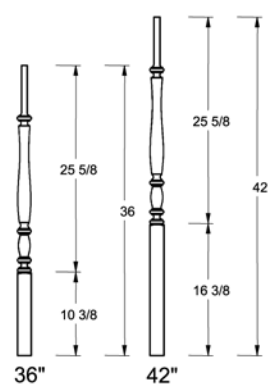

**F-5911**  
1 3/4" Tapered Top

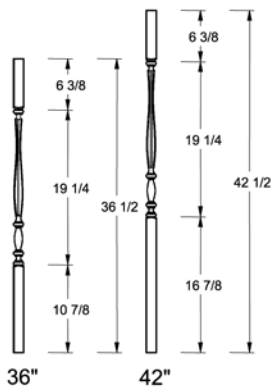

**F-5109 FL**  
1 1/4" Square

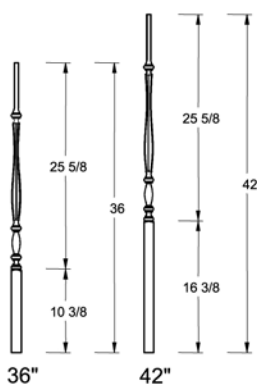

**F-5019 FL**  
1 1/4" Tapered Top

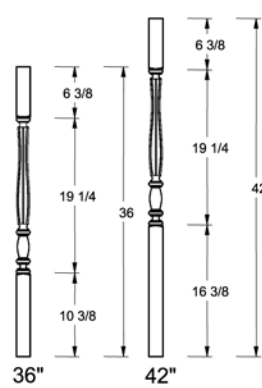

**F-5905 FL**  
1 3/4" Square

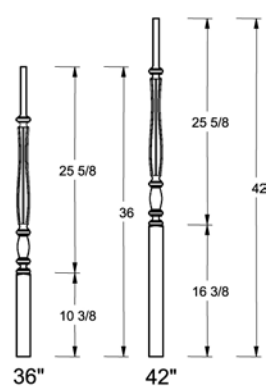

**F-5911 FL**  
1 3/4" Tapered Top



# Mantel Gallery

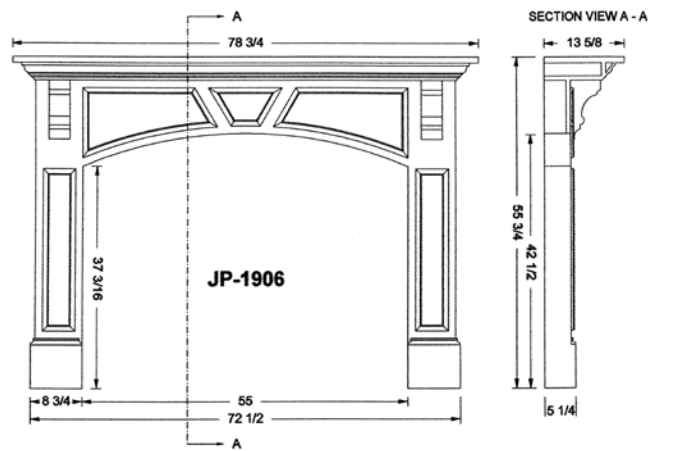
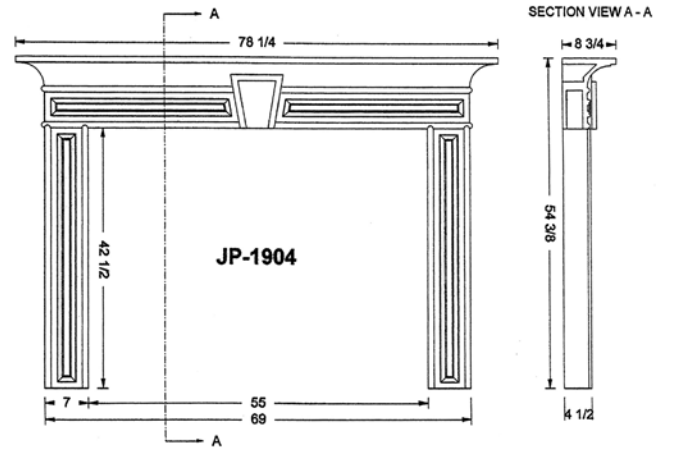
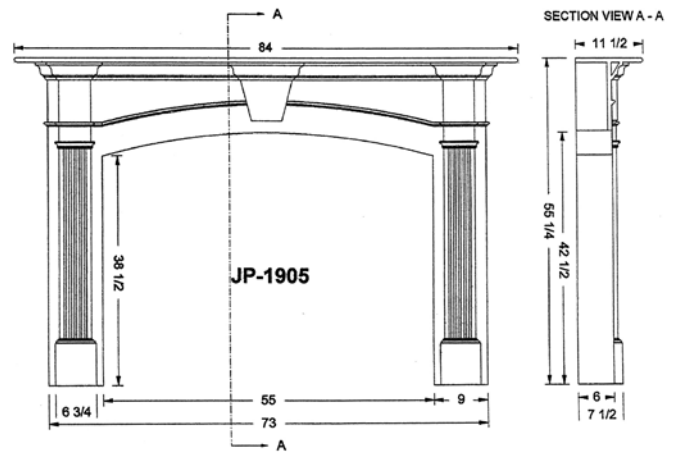

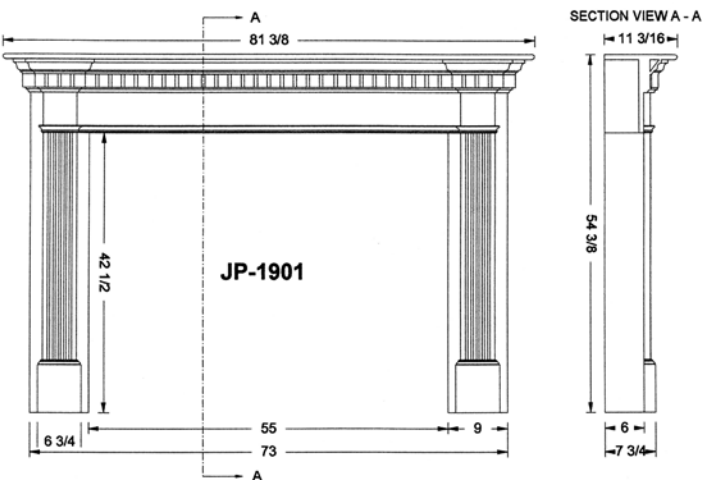
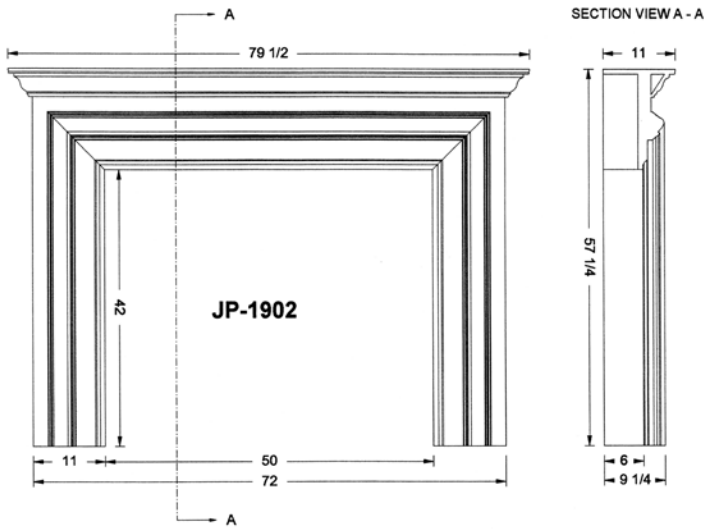
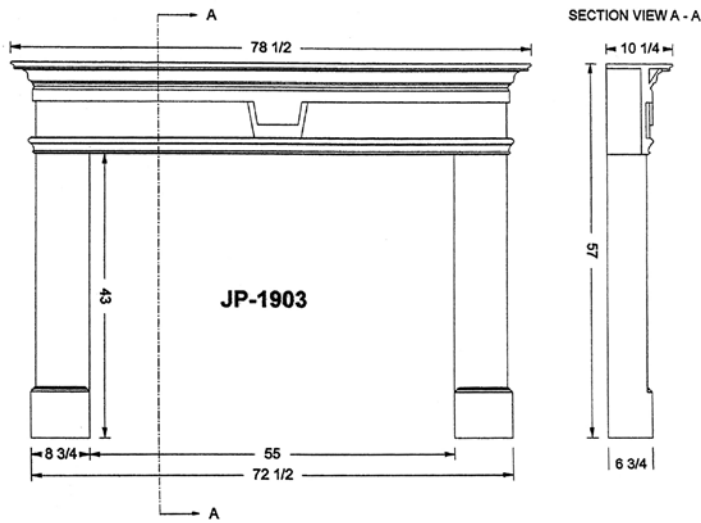



# Turncraft – Poly Classic

## Fiberglass Columns

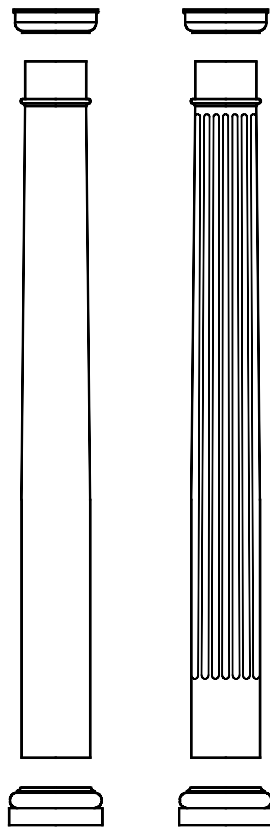

Stock #	Description	Weight	Structural Rating
PC-65	6' x 5'-0" Plain	30 lbs	8,000 lbs
PC-66	6' x 6'-0" Plain	32 lbs	8,000 lbs
PC-68	6' x 8'-0" Plain	43 lbs	8,000 lbs
PC-86	8' x 6'-0" Plain	60 lbs	10,000 lbs
PC-88	8' x 8'-0" Plain	74 lbs	10,000 lbs
PCF-88	8' x 8'-0" Fluted	71 lbs	10,000 lbs
PC-810	8' x 10'-0" Plain	97 lbs	10,000 lbs
PCF-810	8' x 10'-0" Fluted	97 lbs	10,000 lbs
PC-108	10' x 8'-0" Plain	97 lbs	14,000 lbs
PCF-108	10' x 8'-0" Fluted	97 lbs	14,000 lbs
PC-1010	10' x 10'-0" Plain	135 lbs	14,000 lbs
PCF-1010	10' x 10'-0" Fluted	135 lbs	14,000 lbs
PC-1012	10' x 12'-0" Plain	159 lbs	14,000 lbs
PCF-1012	10' x 12'-0" Fluted	159 lbs	14,000 lbs
PC-128	12' x 8'-0" Plain	140 lbs	18,000 lbs
PCF-128	12' x 8'-0" Fluted	140 lbs	18,000 lbs
PC-1210	12' x 10'-0" Plain	182 lbs	18,000 lbs
PCF-1210	12' x 10'-0" Fluted	182 lbs	18,000 lbs
PC-1212	12' x 12'-0" Plain	244 lbs	18,000 lbs
PCF-1212	12' x 12'-0" Fluted	244 lbs	18,000 lbs
PC-1216	12' x 16'-0" Plain	280 lbs	18,000 lbs
PCF-1216	12' x 16'-0" Fluted	280 lbs	18,000 lbs

**Larger sizes are available - Please call for pricing and lead times.** All columns come standard with FRP caps and bases. To order columns without caps and bases please specify when ordering.

**Split Columns** Split columns are available in the sizes listed above. See price catalog for splitting charges. Split columns come with full caps & bases. Caps & bases should be split on the jobsite.

## Ornamental Capitals

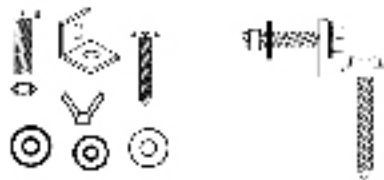

Ornamental Capitals are available in a wide variety of architectural styles for Poly Classic columns and Colonial wood columns as special order items.

Please call for specifications, pricing, and lead time.



## Round Wood Columns

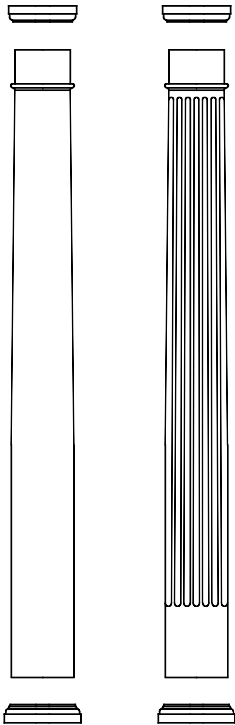

## Pine Wood Columns

## COLONIAL

Stock #	Description	Weight	Structural Rating
TC1066	6" x 6'-0" Plain	15 lbs	2567 lbs
TCF1066	6" x 6'-0" Fluted	15 lbs	2567 lbs
TC1068	6" x 8'-0" Plain	18 lbs	2567 lbs
TCF1068	6" x 8'-0" Fluted	18 lbs	2567 lbs
TC1086	8" x 6'-0" Plain	34 lbs	4114 lbs
TCF1086	8" x 6'-0" Fluted	34 lbs	4114 lbs
TC1088	8" x 8'-0" Plain	38 lbs	4114 lbs
TCF1088	8" x 8'-0" Fluted	38 lbs	4114 lbs
TC0810	8" x 10'-0" Plain	46 lbs	4114 lbs
TCF0810	8" x 10'-0" Fluted	46 lbs	4114 lbs
TC1108	10" x 8'-0" Plain	49 lbs	5497 lbs
TCF1108	10" x 8'-0" Fluted	49 lbs	5497 lbs
TC1110	10" x 10'-0" Plain	59 lbs	5497 lbs
TCF1110	10" x 10'-0" Fluted	59 lbs	5497 lbs
TC1112	10" x 12'-0" Plain	68 lbs	5497 lbs
TCF1112	10" x 12'-0" Fluted	68 lbs	5497 lbs
TC1128	12" x 8'-0" Plain	63 lbs	6620 lbs
TCF1128	12" x 8'-0" Fluted	63 lbs	6620 lbs
TC1210	12" x 10'-0" Plain	69 lbs	6620 lbs
TCF1210	12" x 10'-0" Fluted	69 lbs	6620 lbs
TC1212	12" x 12'-0" Plain	85 lbs	6620 lbs
TCF1212	12" x 12'-0" Fluted	85 lbs	6620 lbs

## Square

Wood Columns  
(Non Structural)

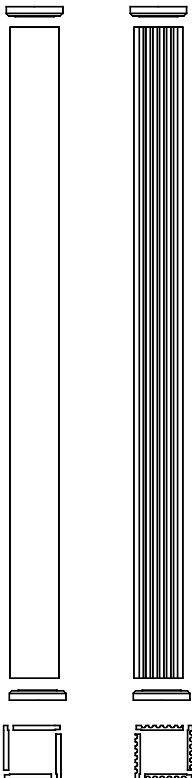

**Larger sizes are available - Please call for pricing and lead times.**

All columns come standard with polyurethane caps and bases. To order columns without caps and bases please specify when ordering. Ornamental Capitals are available. Call for quotation.

**Split Columns** Split columns are available in the sizes listed above. See price catalog for splitting charges. Split columns come with full caps & bases. Caps & bases should be split on the jobsite.

## Square Columns

Stock #	Description	Weight	Structural Rating
TC6001	6" x 8'-0" Plain	23 lbs	Non-Structural
TCF6001	6" x 8'-0" Fluted	23 lbs	Non-Structural
TC6003	8" x 8'-0" Plain	29 lbs	Non-Structural
TCF6003	8" x 8'-0" Fluted	29 lbs	Non-Structural
TC6004	8" x 10'-0" Plain	34 lbs	Non-Structural
TCF6004	8" x 10'-0" Fluted	34 lbs	Non-Structural

**Note: Square columns come standard with wood caps and bases. Square columns are shipped unassembled.**



# Turncraft

**Note:** Porch Posts are constructed of treated & laminated wood materials. They should be finished immediately upon installation.

3-1/4" Post Solid Laminated  
 4-1/4" Post Hollow Laminated  
 5-1/4" Post Hollow Laminated



**Colonial  
Primed**



**New Orleans**



**Lamp Post**

**Quick-Mount™**  
 Porch Post Fastener  
 Prevents Water Damage &  
 Increases the life of the post.

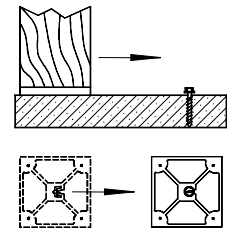

A2101 3-1/4" Post  
 A2102 4-1/4" Post  
 A2103 5-1/4" Post

Colonial Post Stock #	Size	Turned Area	Top	Bottom	Weight	Load Capacity
3148PR	3-1/4" x 8'-0"	40"	14"	42"	15 lbs	1000 lbs
3410PR	3-1/4" x 10'-0"	40"	24"	56"	20 lbs	1000 lbs
3158PR	4-1/4" x 8'-0"	40"	14"	42"	23 lbs	3000 lbs
3510PR	4-1/4" x 10'-0"	40"	24"	56"	29 lbs	3000 lbs
3168PR	5-1/4" x 8'-0"	40"	14"	42"	27 lbs	5800 lbs
3610PR	5-1/4" x 10'-0"	40"	24"	56"	31 lbs	5800 lbs

New Orleans Post Stock #	Size	Turned Area	Top	Bottom	Weight	Load Capacity
N148	3-1/4" x 8'-0"	40-3/8"	14"	41-5/8"	15 lbs	1000 lbs
N149	3-1/4" x 9'-0"	40-3/8"	14"	53-5/8"	20 lbs	1000 lbs
N158	4-1/4" x 8'-0"	40-3/8"	14"	41-5/8"	23 lbs	3000 lbs
N159	4-1/4" x 9'-0"	40-3/8"	14"	53-5/8"	29 lbs	3000 lbs
N168	5-1/4" x 8'-0"	40-3/8"	14"	41-5/8"	27 lbs	5800 lbs
N169	5-1/4" x 9'-0"	40-3/8"	14"	53-5/8"	31 lbs	5800 lbs

**Lamp Post** (features a full-length open center for electrical installation.)

3078	4-1/4" x 8'-0"	40-1/2"	N/A	55-1/2"	23 lbs	Non-Structural
------	----------------	---------	-----	---------	--------	----------------



## Deco Series PVC Column

"Columns on a Budget"

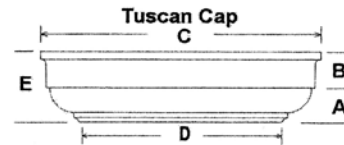
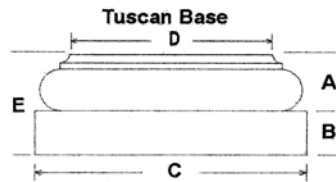
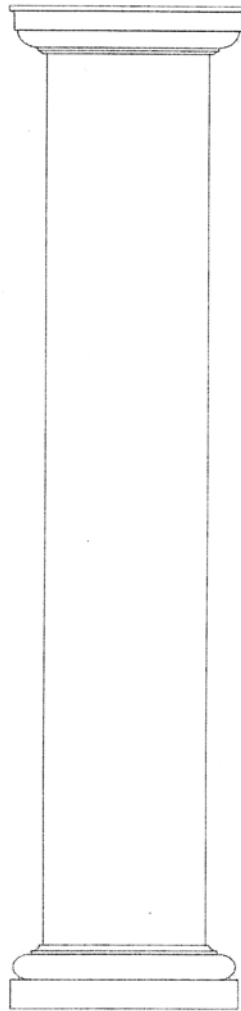

Design Number	Tuscan Base					Tuscan Cap				
	A	B	C	D	E	A	B	C	D	E
PVC-7	1-1/8"	1-1/2"	9-1/2"	6-5/8"	2-5/8"	1-7/8"	1-1/2"	9-1/2"	6-5/8"	3-3/8"
PVC-9	1-1/2"	2"	12"	8-5/8"	3-1/2"	2-1/4"	1-3/4"	12"	8-5/8"	4"
PVC-10.5	1-3/4"	2-1/2"	14"	10-5/8"	4-1/4"	2-3/4"	2-1/4"	14"	10-5/8"	5"
PVC-11	1-3/4"	2-1/2"	14"	10-3/4"	4-1/4"	2-3/4"	2-1/4"	14"	10-3/4"	5"
PVC-12.5	2"	2-3/4"	16"	12-1/2"	4-3/4"	3-3/8"	2-5/8"	16"	12-1/2"	6"
PVC-13	2"	2-3/4"	16"	12-3/4"	4-3/4"	3-3/8"	2-5/8"	16"	12-3/4"	6"